

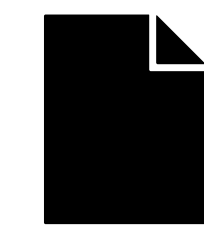

THE ZoNE - eXpanding possibilities

hand-code

III II MARCUS NEUSTETTER



summary



credits



activities



Francis Aupiais and Frédéric Gadmer, Collection Archives de la Planète, Musée départemental Albert-Kahn, Département des Hauts-de-Seine



Marcus Neustetter, South Africa .Photo: Zivanai Matangi

THE ZoNE - eXpanding possibilities

hand-code

III II MARCUS NEUSTETTER

Summary

The present moment has many of us deeply immersed in the digital and the artificial. What is the value in shifting and diversifying our attention to more deliberately include the artisanal and the natural, to deliberately turn our curiosity to the unexpected, as an attempt to reconnect with the intuitive?

hand-code, is a practice-led artist research process. Marcus Neustetter explores the dynamics between analogue and digital approaches in the act of making and collaborating. He engages with documented and practiced handicrafts, materials, and tools from the past and in the present.

Drawing from diverse contexts and conditions, the exploration follows the artists movements between countries across Africa and Europe. The current journey ranges from rural and urban contexts in Benin (Ouadah, Setou, Kadé, Porto Novo, Dassa), South Africa (Johannesburg, Port Elizabeth), Austria (Murau, Vienna), France (Paris) and the Czech Republic (Usti nad Labem).

Conscious of the social, political, economic and environmental complexities in the sites of engagement, Neustetter has crafted a sensitive approach, each time seeking out a safe space for identifying common ideas and sharing personal vulnerabilities in the process of creating and inventing. Here the studio is not a physical space but rather a mobile offering, Neustetter repeatedly finds collaborative and spontaneous actions with others, ranging from intimate co-productions to large-scale public light projections. Evidence of communing and practice is created through process drawings, photographs, films and audio recordings.

The undertaking pulls scientific, philosophical, ethnographic, anthropological and artistic perspectives and debates into a shared space of experimenting with craft traditions and digital tools and media. Is it a project seeking to birth new provocations and forms, both in the hand-made and digitally coded.

hand-code is informed by and contributes to the *THE ZoNE - eXpanding possibilities* philosophical and scientific research collaboration and outreach. On the journey over the past 8 months, Neustetter's artistic approach has been applied to various projects and partners, seeding the first *hand-code* network through dialogue and experience.



[back](#)



THE ZoNE - eXpanding possibilities

hand-code

III II MARCUS NEUSTETTER

affiliates / participants / hosts / supporters / funders

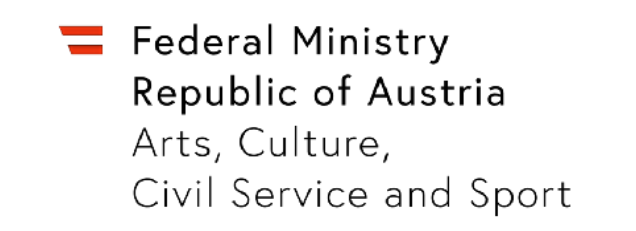
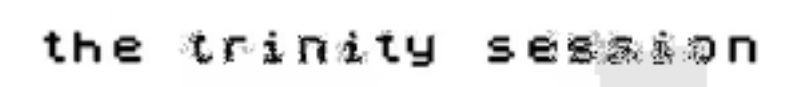
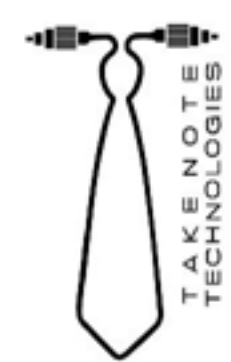

back

the following activities were executed as part of the **hand-code** practice-led research process
by Marcus Neustetter from June 2023 - February 2024

THE ZoNE - eXpanding possibilities

hand-code

III II MARCUS NEUSTETTER

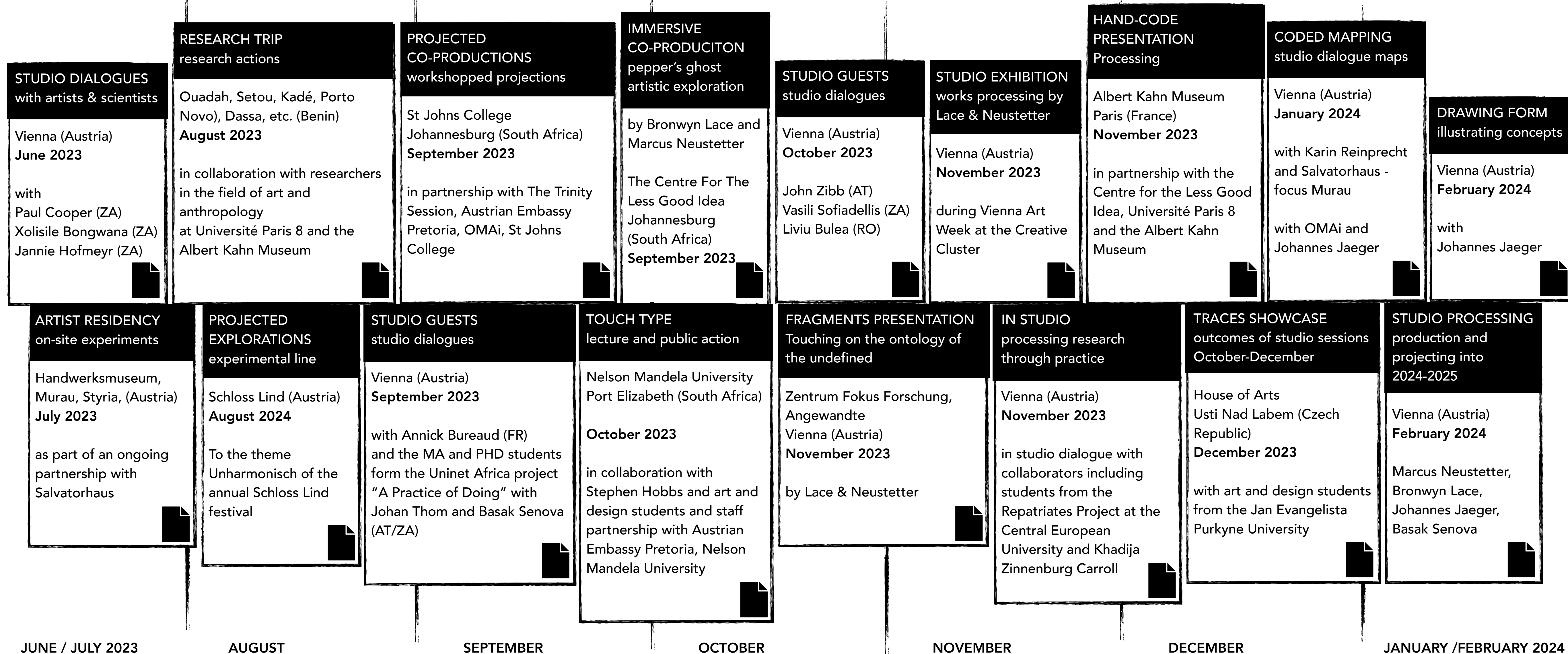

back



THE ZoNE - eXpanding possibilities
hand-code
III II MARCUS NEUSTETTER



STUDIO DIALOGUES
with artists & scientists

Vienna (Austria)
June 2023

with Xolisile Bongwana (ZA)



STUDIO DIALOGUES
with artists & scientists

Vienna (Austria)
June 2023

with
Paul Cooper (ZA)



THE ZoNE - eXpanding possibilities

hand-code

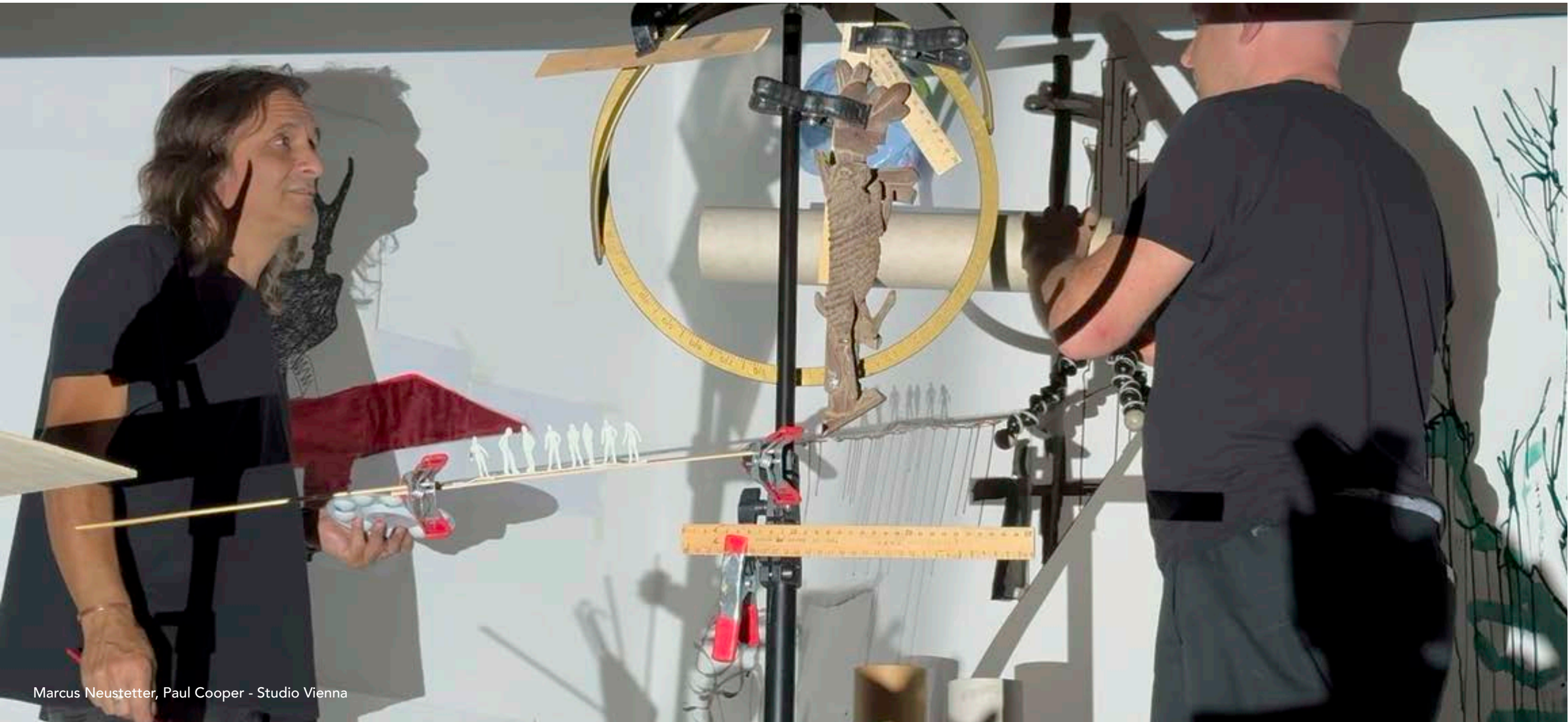
III II MARCUS NEUSTETTER



 back

 menu  back  next



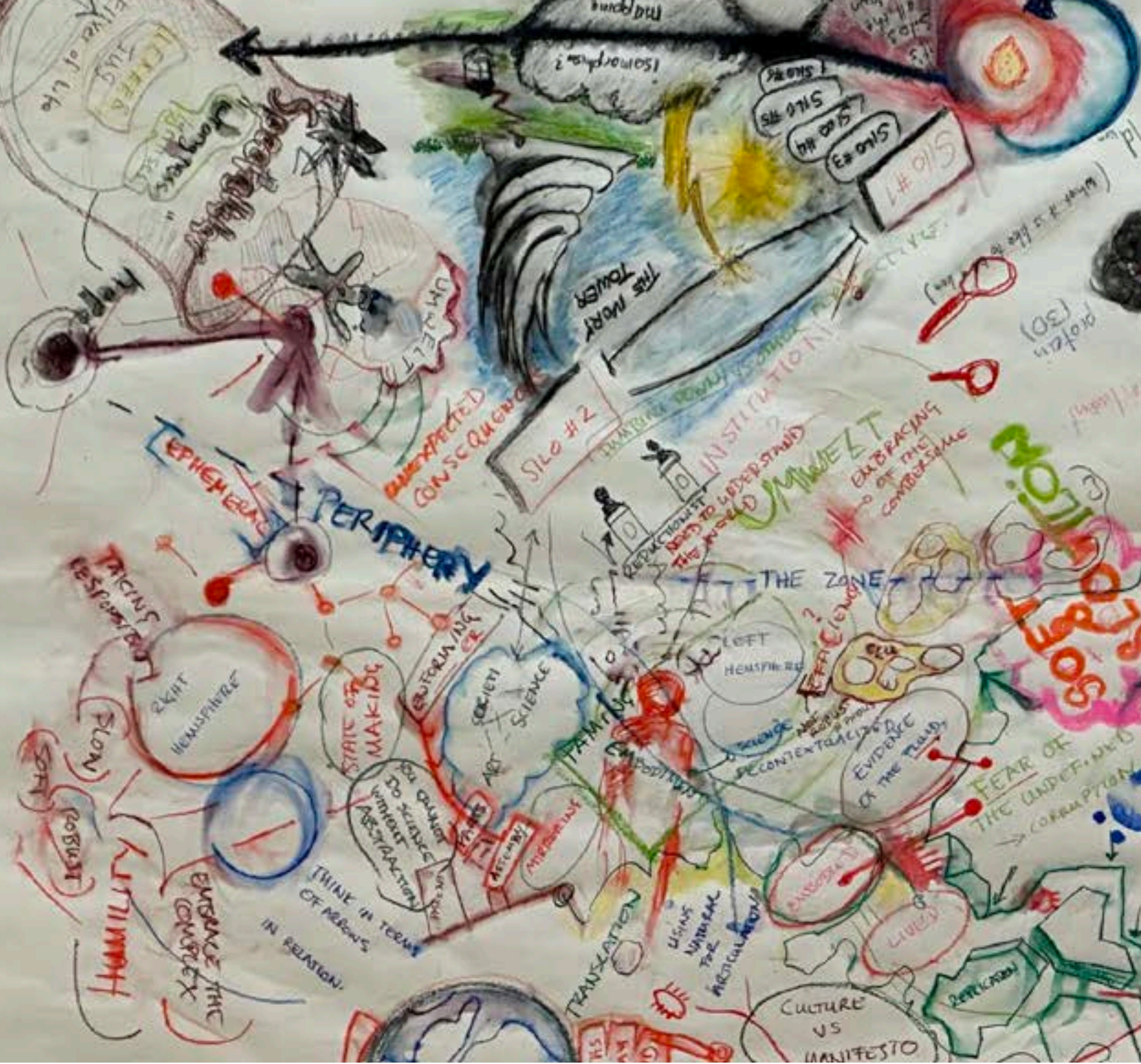

STUDIO DIALOGUES
with artists & scientists

Vienna (Austria)
June 2023

with
Johannes Jaeger, Bronwyn Lace
and Jannie Hofmeyr (ZA)

THE ZoNE - eXpanding possibilities
hand-code
III II MARCUS NEUSTETTER



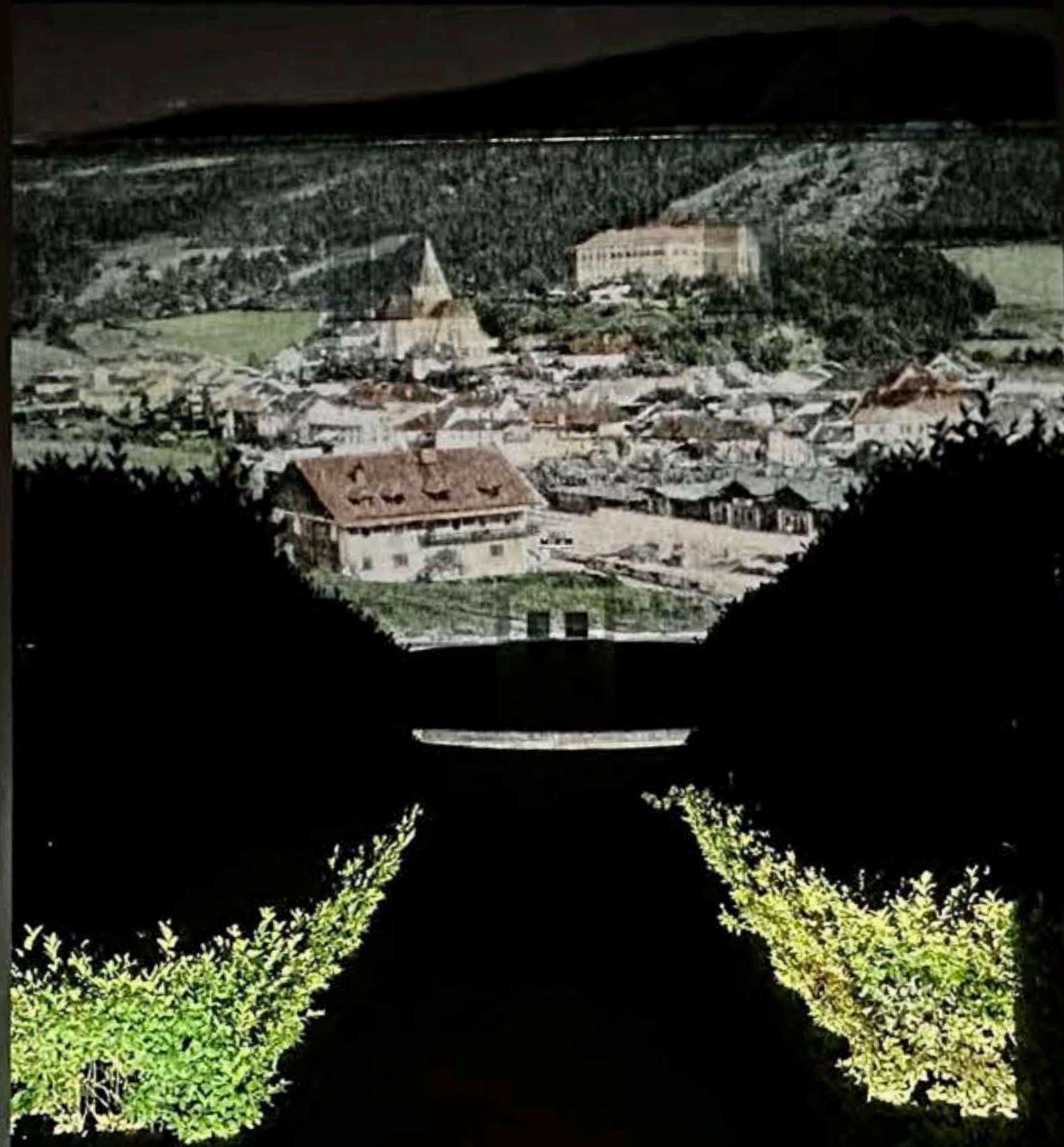

Marcus Neustetter - Murauer Handwerksmuseum

ARTIST RESIDENCY
on-site experiments

Handwerksmuseum,
Murau, Styria, (Austria)
July 2023

Marcus Neustetter
as part of an ongoing
partnership with
Salvatorhaus

THE ZoNE - eXpanding possibilities

hand-code

III II MARCUS NEUSTETTER



menu back

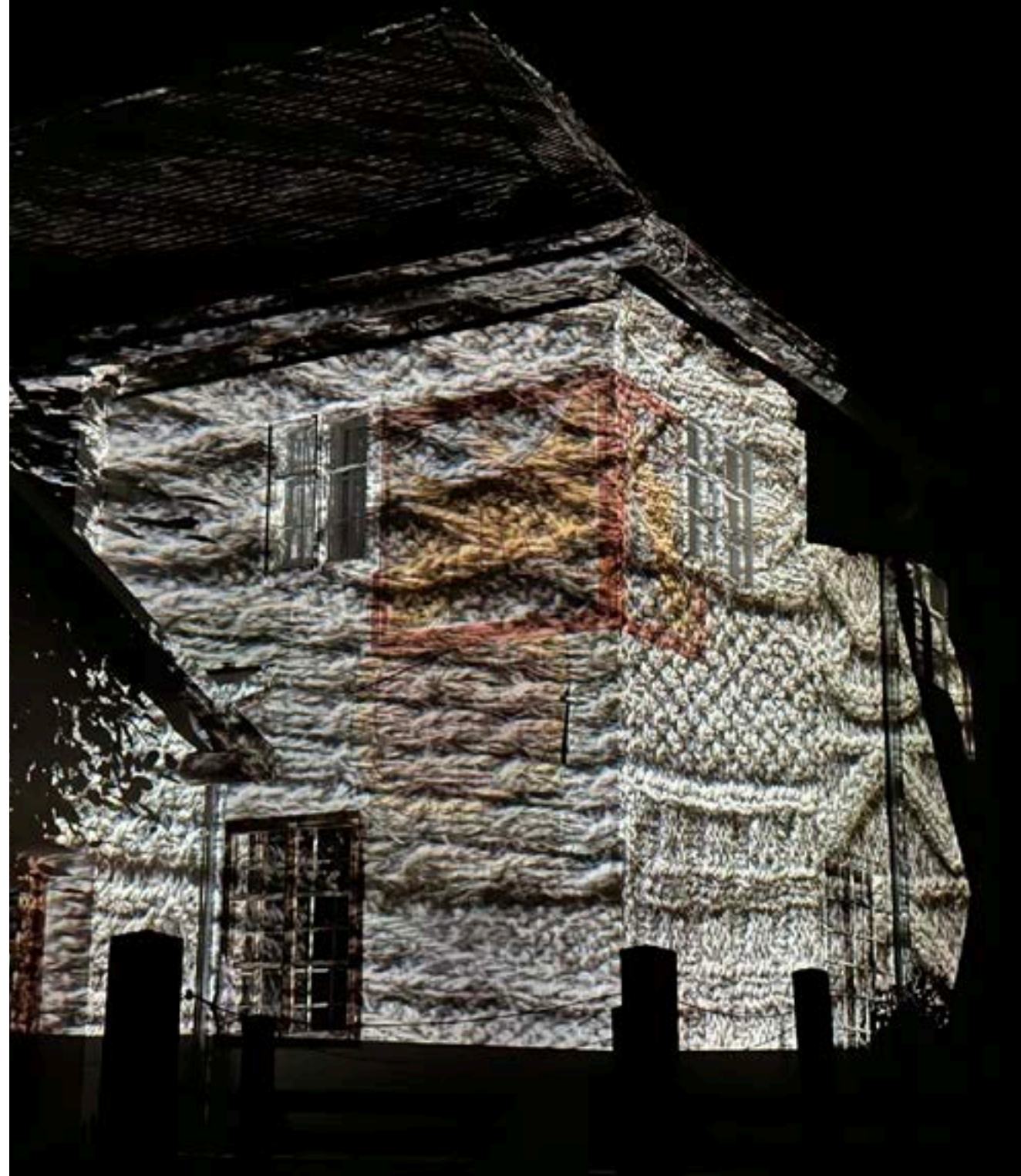



THE ZoNE - eXpanding possibilities
hand-code
III II MARCUS NEUSTETTER



RESEARCH TRIP
research actions

Ouah, Setou, Kadé, Porto
Novo, Dassa, etc. (Benin)
August 2023

Marcus Neustetter in
collaboration with researchers in
the field of art and anthropology
at Université Paris 8 and the
Albert Kahn Museum



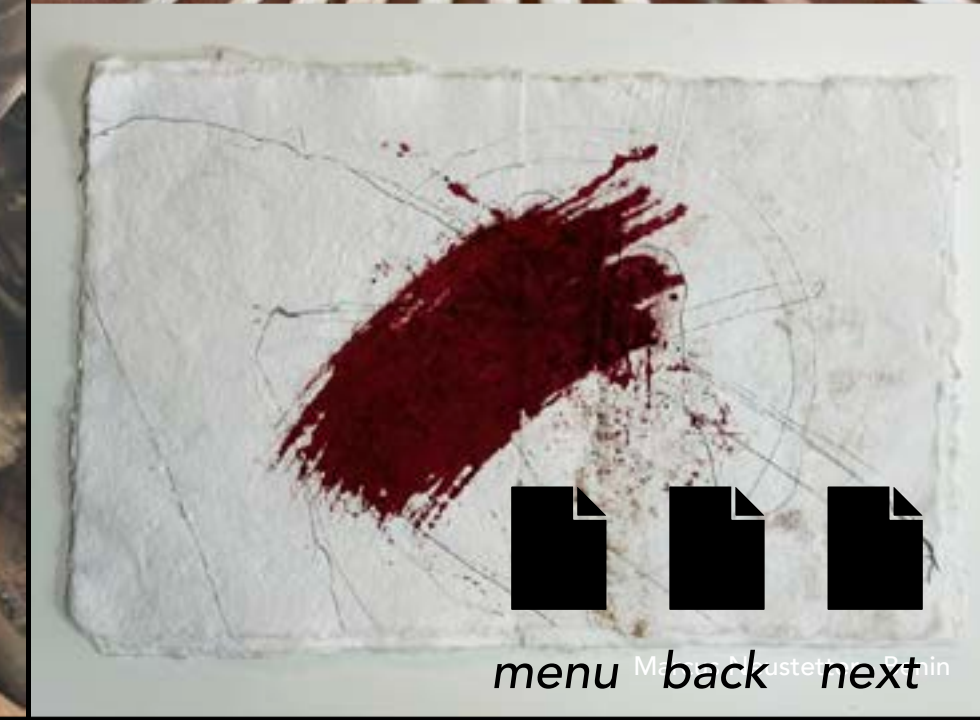
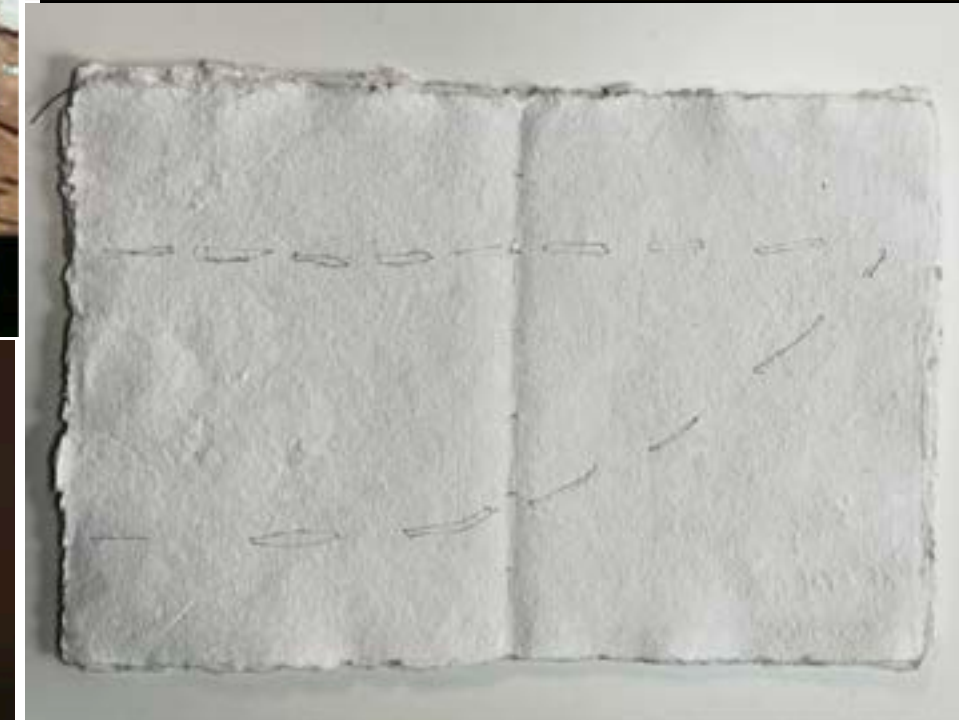
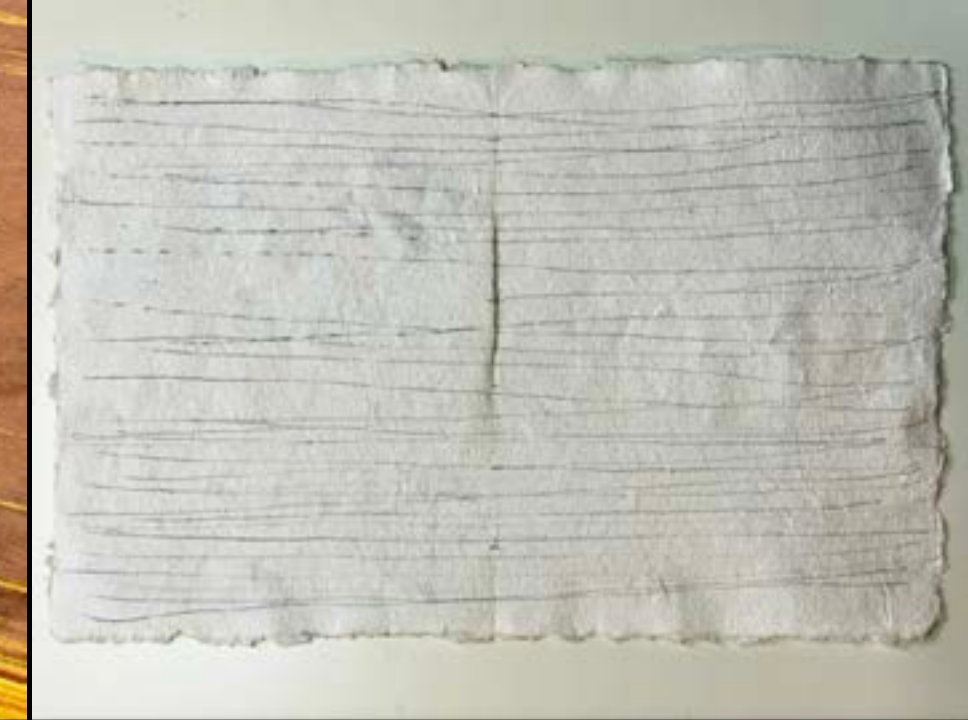

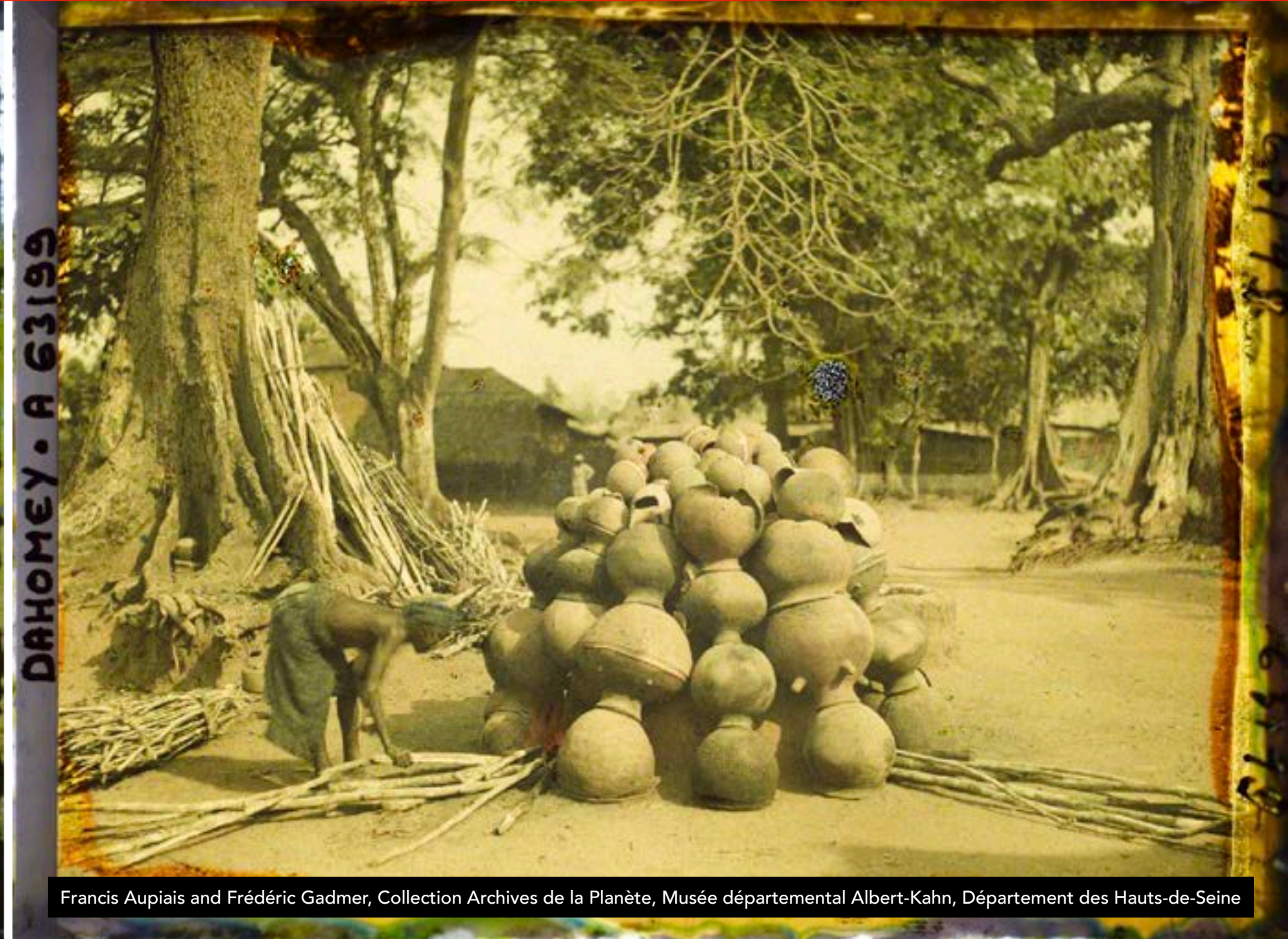

Francis Aupiais and Frédéric Gadmer, Collection Archives de la Planète, Musée départemental Albert-Kahn, Département des Hauts-de-Seine



Francis Aupiais and Frédéric Gadmer, Collection Archives de la Planète, Musée départemental Albert-Kahn, Département des Hauts-de-Seine



Marcus Neustetter - Benin

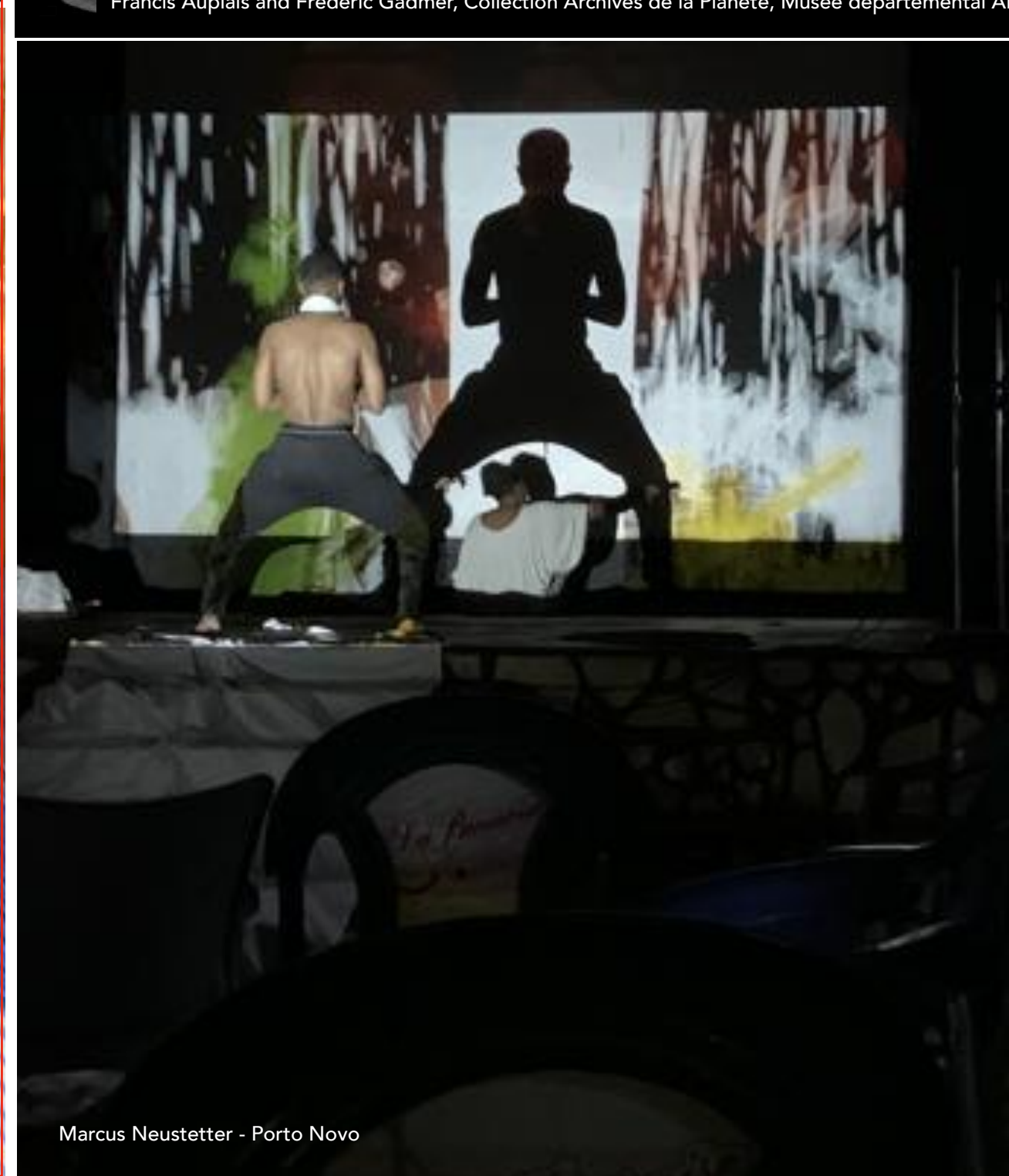

Marcus Neustetter - Porto Novo

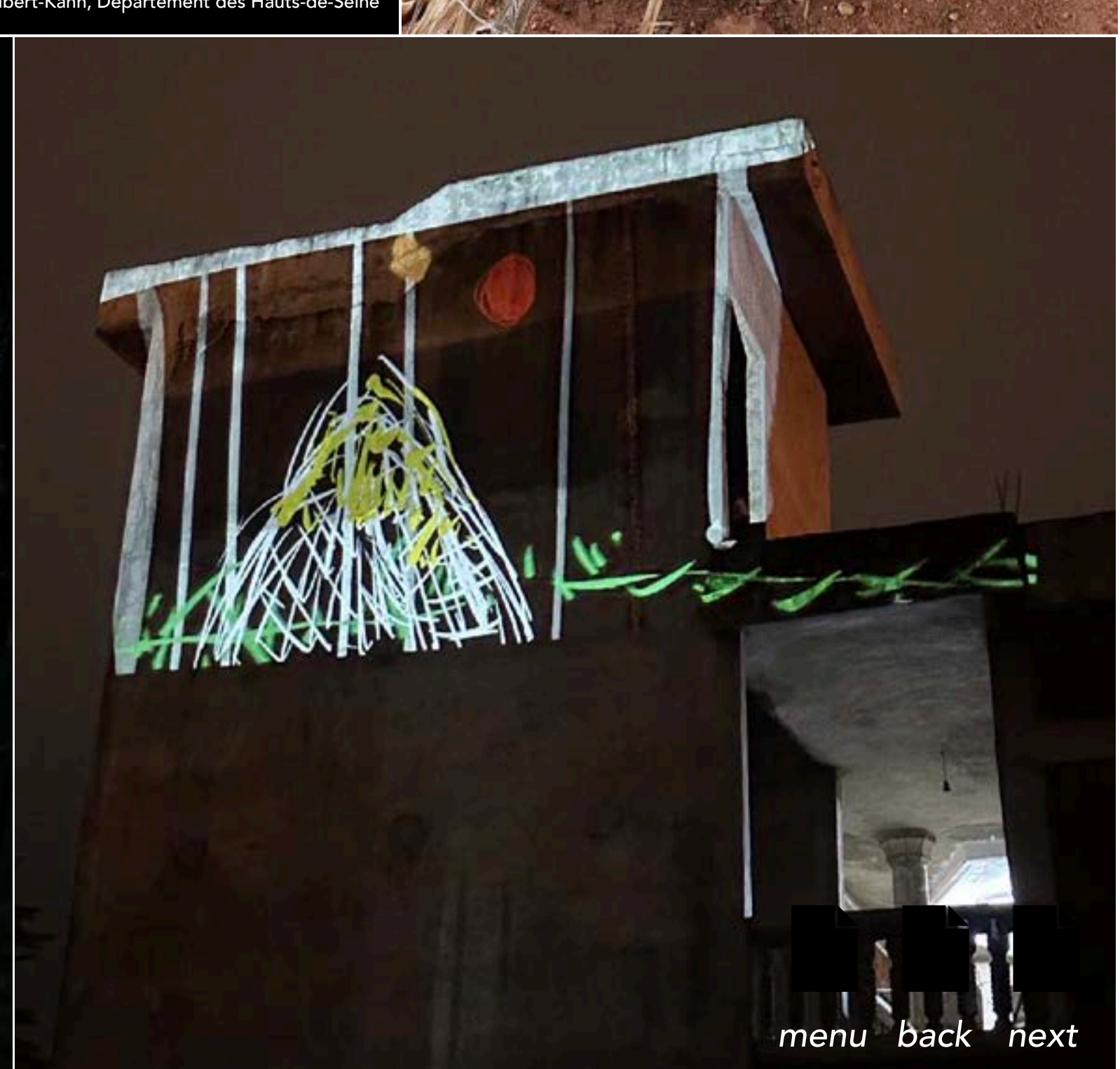

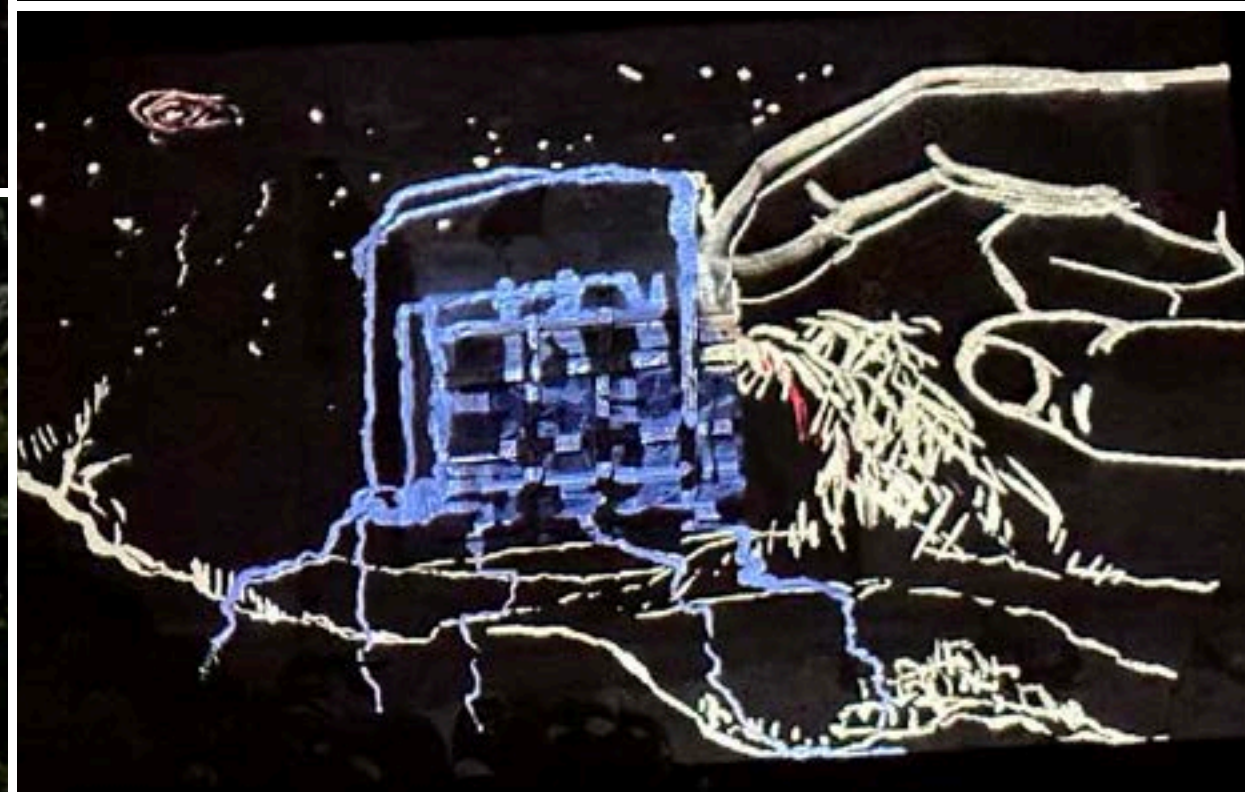
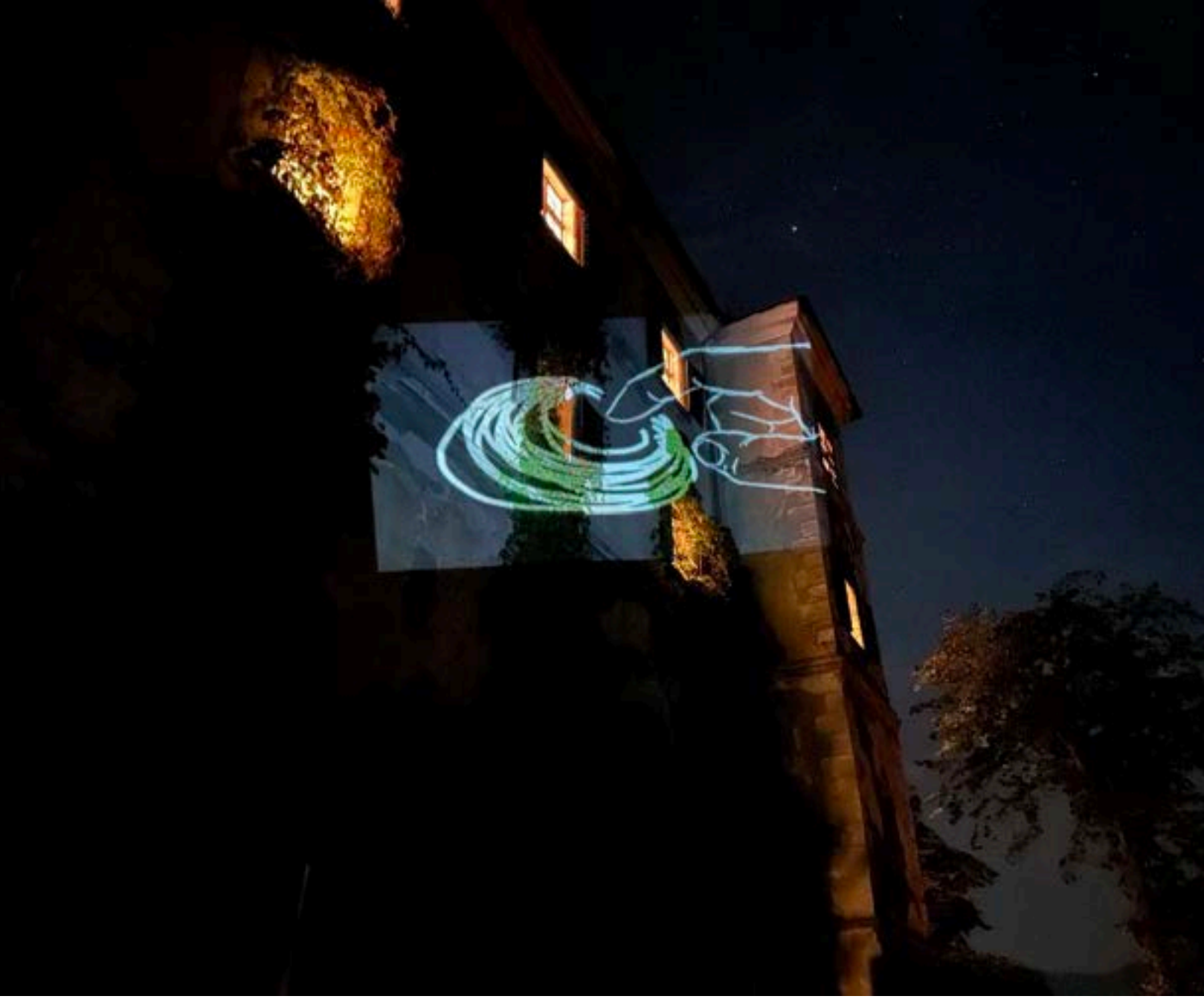

THE ZoNE - eXpanding possibilities
hand-code
III II MARCUS NEUSTETTER



PROJECTED EXPLORATIONS
experimental line

Schloss Lind (Austria)
August 2024

Marcus Neustetter
to the theme *Unharmonisch* of the annual Schloss Lind festival

Marcus Neustetter - Schloss Lind



Marcus Neustetter and OMAi - St Johns College

THE ZoNE - eXpanding possibilities
hand-code
III II MARCUS NEUSTETTER



PROJECTED CO-PRODUCTIONS
workshopped projections

St Johns College
Johannesburg (South Africa)
September 2023

Marcus Neustetter, OMAi and St John's
Collage students
in partnership with The Trinity Session,
Austrian Embassy Pretoria, St Johns College



menu back next

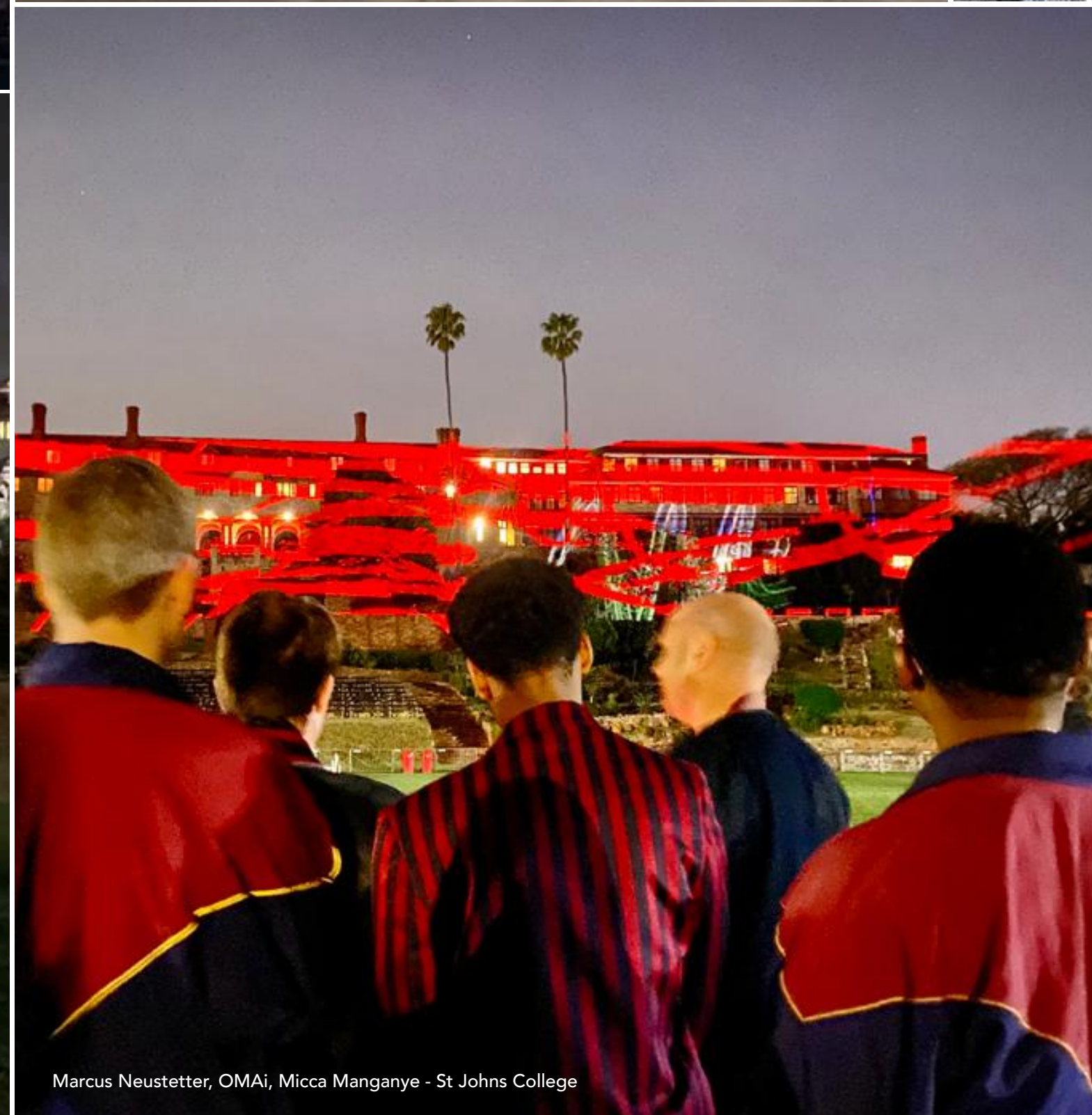

Marcus Neustetter, OMAi, Micca Manganye - St Johns College

Marcus Neustetter, OMAi, Micca Manganye - St Johns College

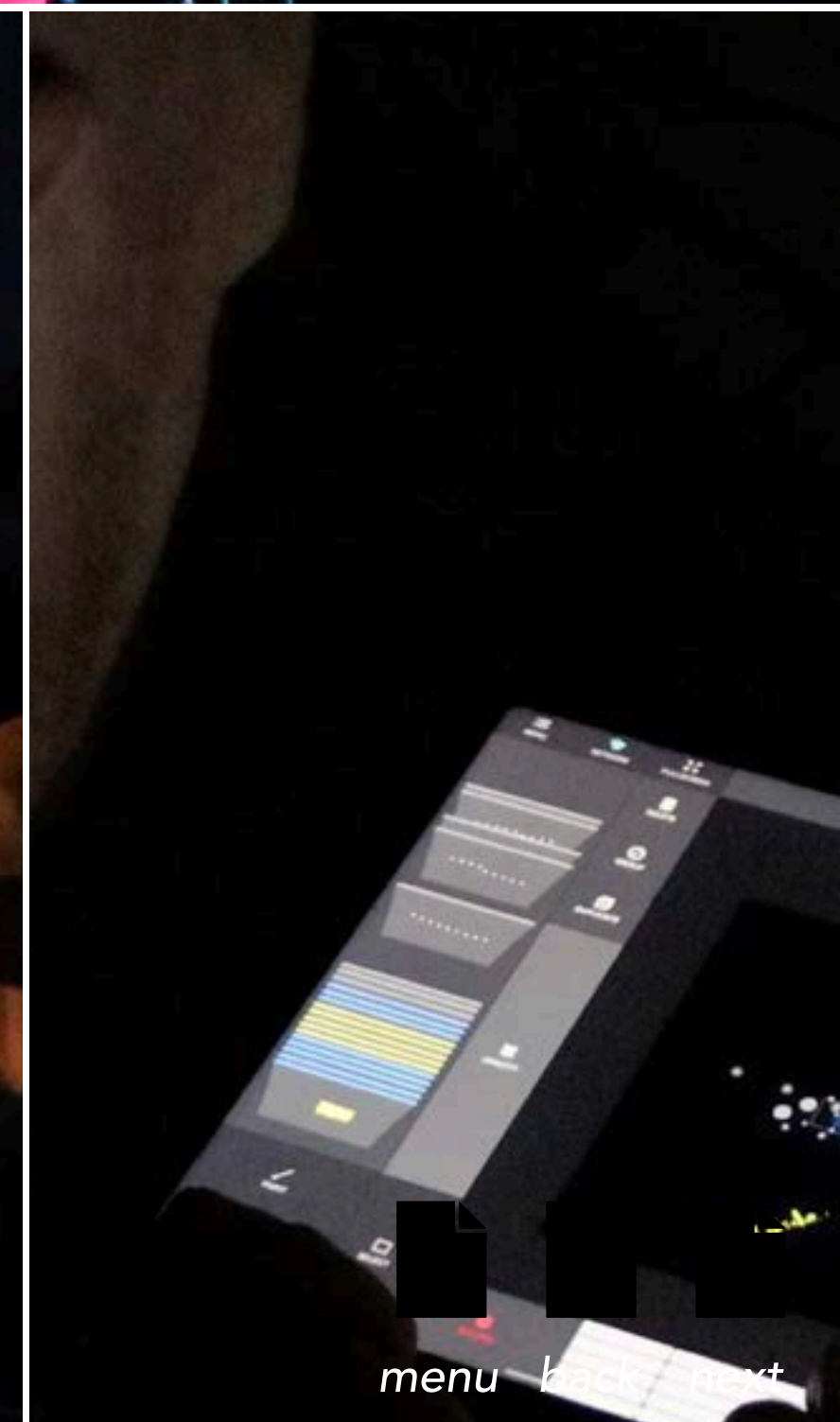

Marcus Neustetter and OMAi - St Johns College

Marcus Neustetter and OMAi - St Johns College

menu  



Marcus Neustetter - Studio Vienna

THE ZoNE - eXpanding possibilities

hand-code

III II MARCUS NEUSTETTER

STUDIO GUESTS
studio dialogues

Vienna (Austria)
September 2023

Marcus Neustetter and Johannes Jaeger
with Annick Bureaud (FR)

and the MA and PHD students from the Uninet Africa
project "A Practice of Doing" with Johan Thom and
Basak Senova (AT/ZA)



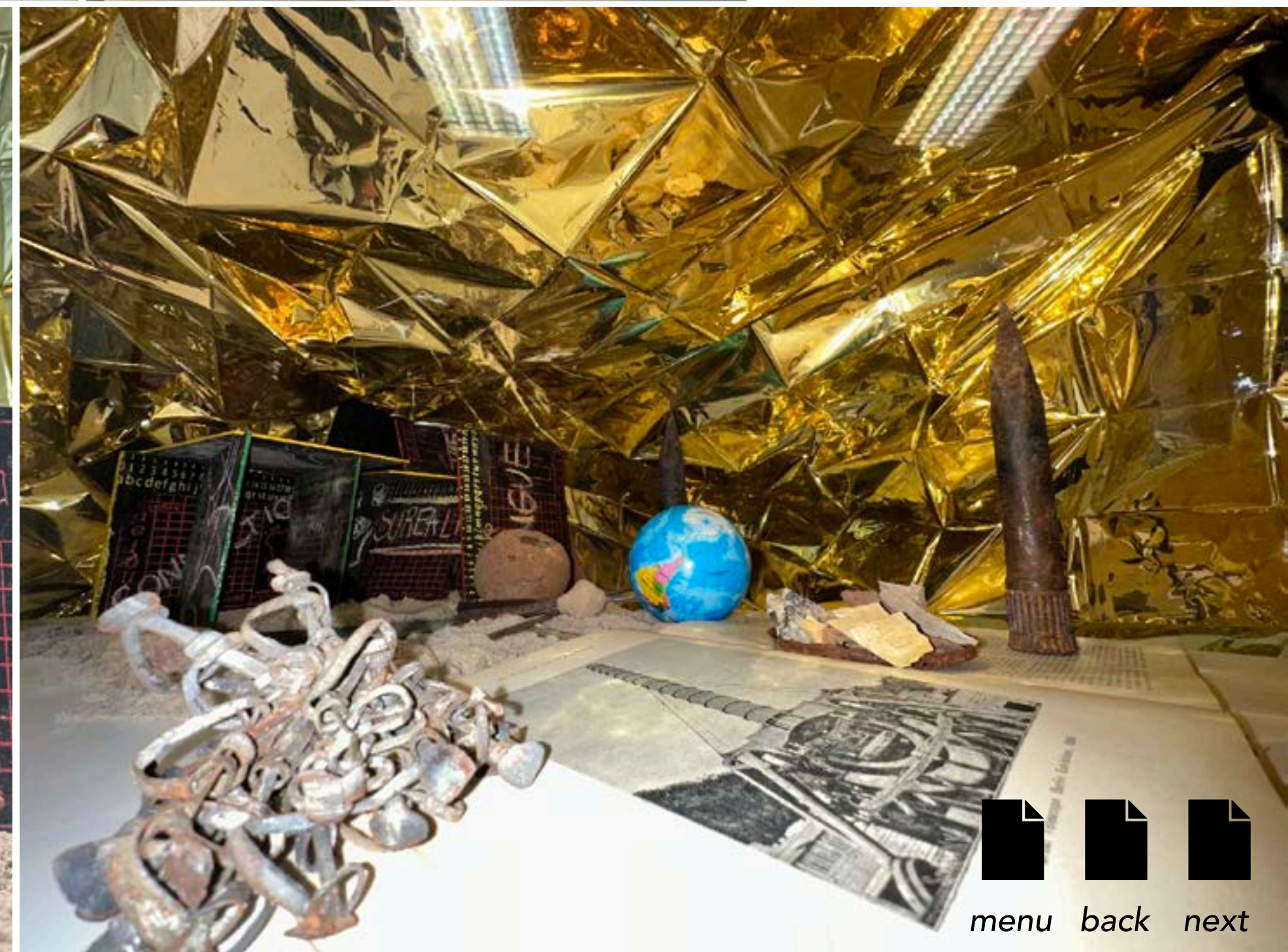



Bronwyn Lace, Katlego Letsholonyana, Sello Ramolahloane & Chorus - The Centre For The Less Good Idea

IMMERSIVE CO-PRODUCION
pepper's ghost artistic exploration

Bronwyn Lace

The Centre For The Less Good Idea
Johannesburg (South Africa)
September 2023

THE ZoNE - eXpanding possibilities

BRONWYN LACE





THE ZoNE - eXpanding possibilities

hand-code

III II MARCUS NEUSTETTER

IMMERSIVE CO-PRODUCITON
artistic exploration

Marcus Neustetter drawings and projection

The Centre For The Less Good Idea
Johannesburg (South Africa)
September 2023

This Death Here...
performance by Jennie Reznek, Mark Fleishman, Neo Muyanga.

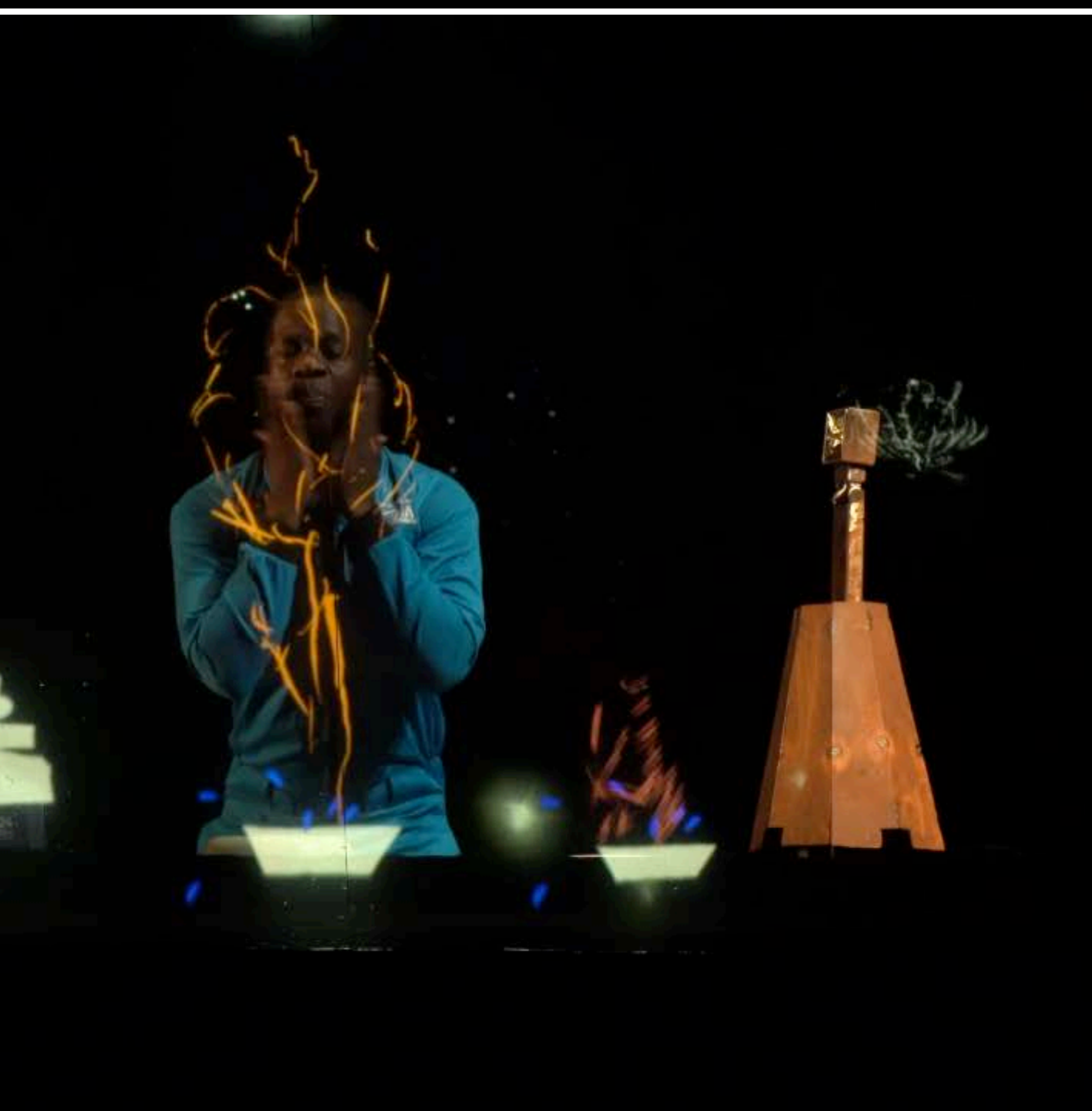
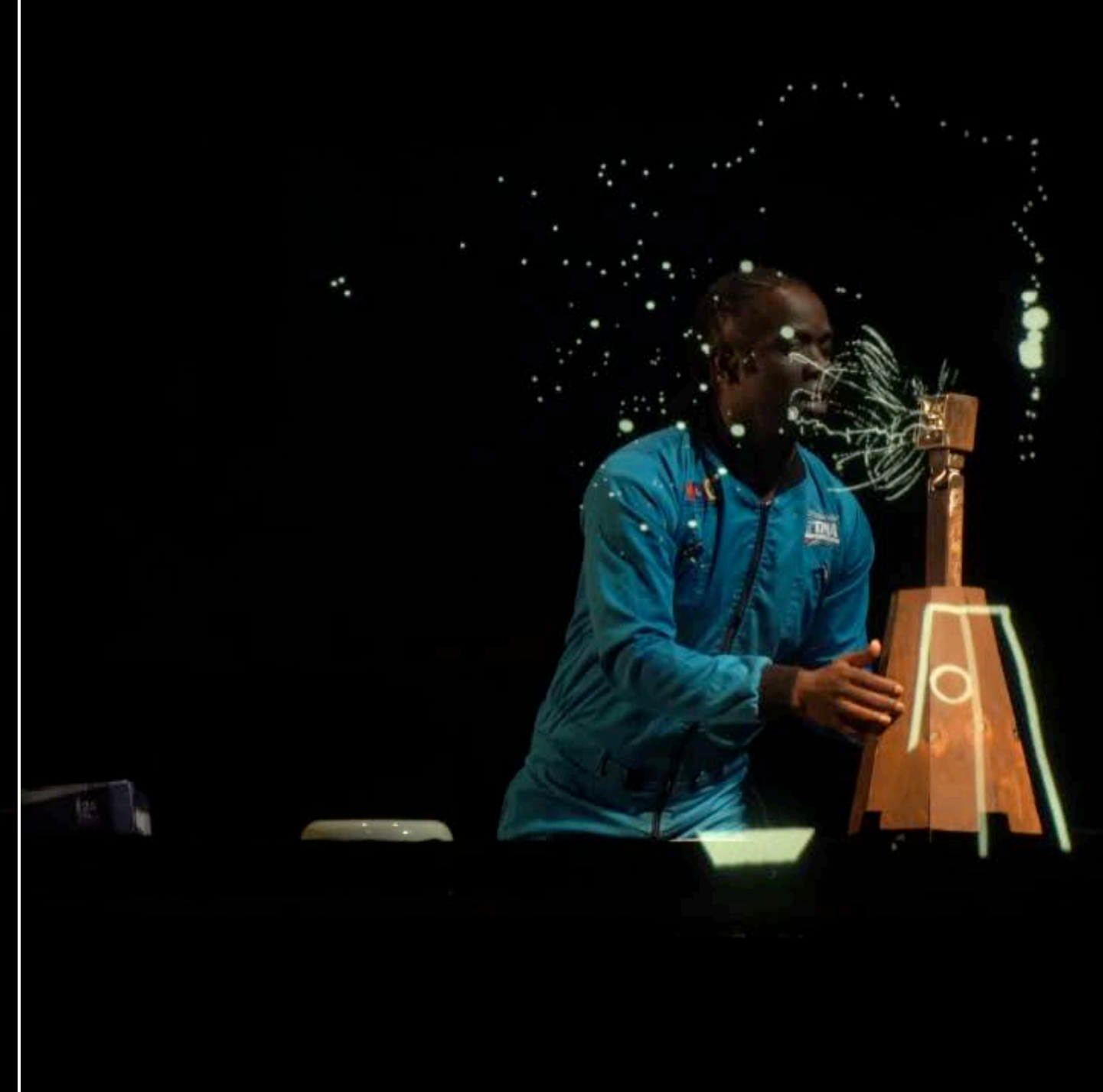

IMMERSIVE CO-PRODUCITON
pepper's ghost artistic exploration

The Centre For The Less Good Idea
Johannesburg (South Africa)
September 2023

Marcus Neustetter, OMAi and
Micca Manganye

in partnership with The Centre For
The Less Good Idea, Austrian
Embassy Pretoria

THE ZoNE - eXpanding possibilities

hand-code

III II MARCUS NEUSTETTER



NELSON MANDELA

UNIVERSITY

The Faculty of Humanities and the Department of Visual Arts
invite you to attend

TOUCH TYPE

An Artist's Talk and experimental art-based project by
artist Stephen Hobbs and NMU Adjunct Professor, Marcus Neustetter

Monday 2 October 2023

09h30 - 12h00

Artist's Talk

K51, K-Block, Dept of Visual Arts

North Campus

Summerstrand

19h00 - 22h00

Experimental Building

Projection

Bird Street Gallery

20 Bird Street, Central

Stephen Hobbs and Marcus Neustetter
reflect on two decades of Trinity Session
project work that shifts perceptions of
space and place through socially
engaged actions in public space using
video and light as a core medium.

More information: 041 504 3256



THE ZoNE - eXpanding possibilities

hand-code

III II MARCUS NEUSTETTER



TOUCH TYPE

lecture and public action

Nelson Mandela University
Port Elizabeth (South Africa)
October 2023

Marcus Neustetter in collaboration with Stephen Hobbs

with art-design students and staff partnership with Austrian Embassy Pretoria, Nelson
Mandela University. experimenting with local content and projection on the Bird Street
Gallery and the NMU Planetarium



menu back next

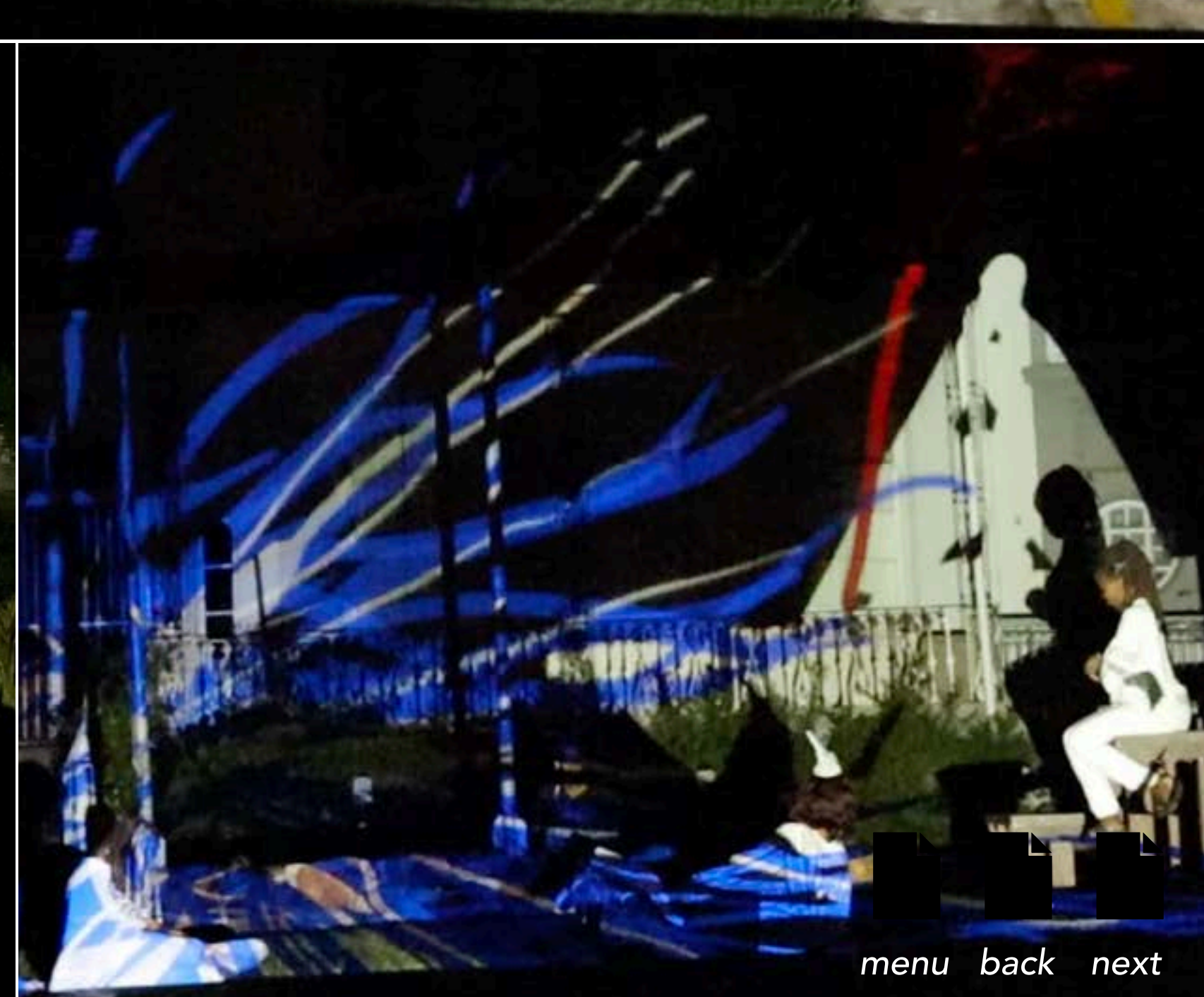
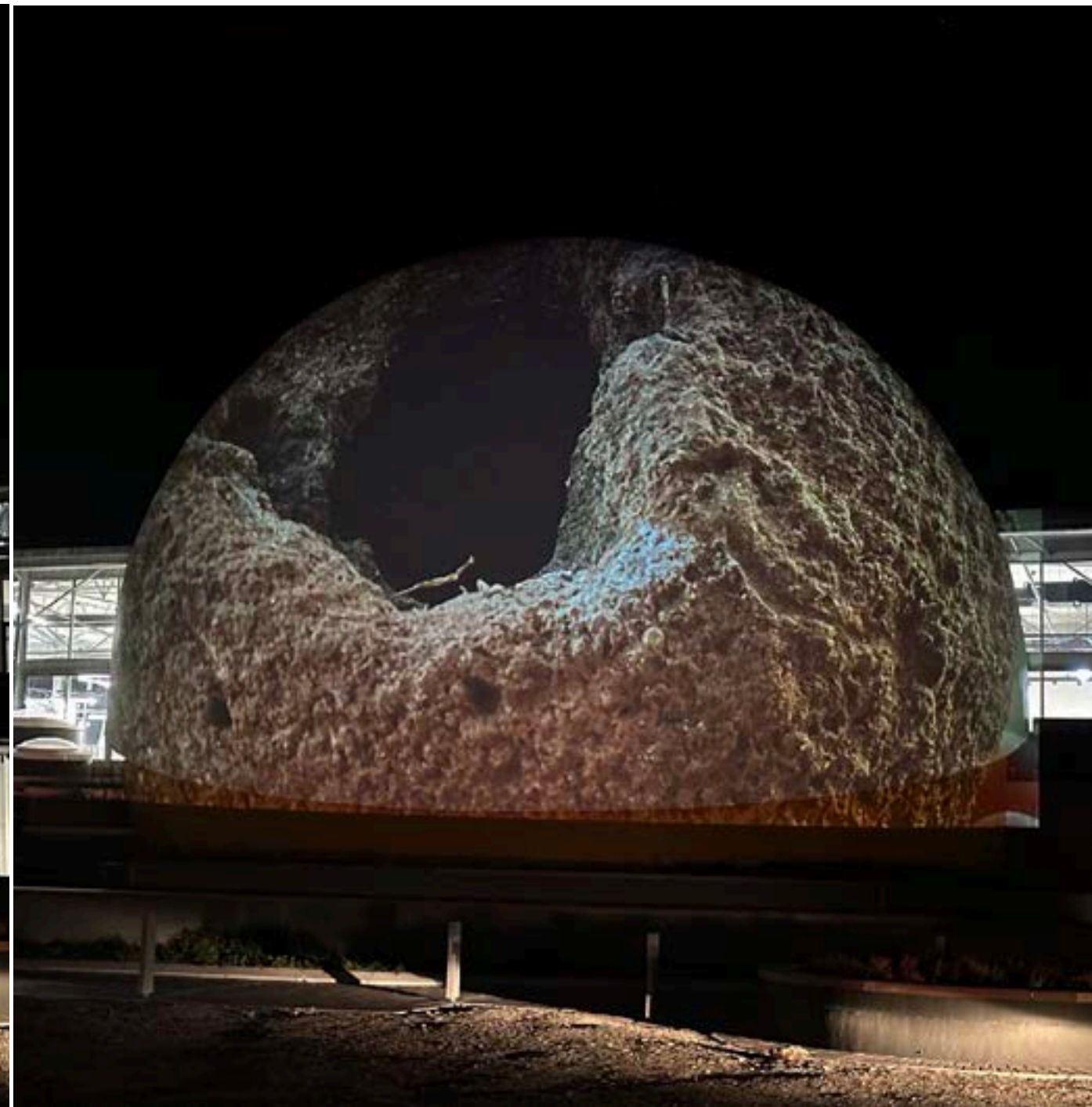

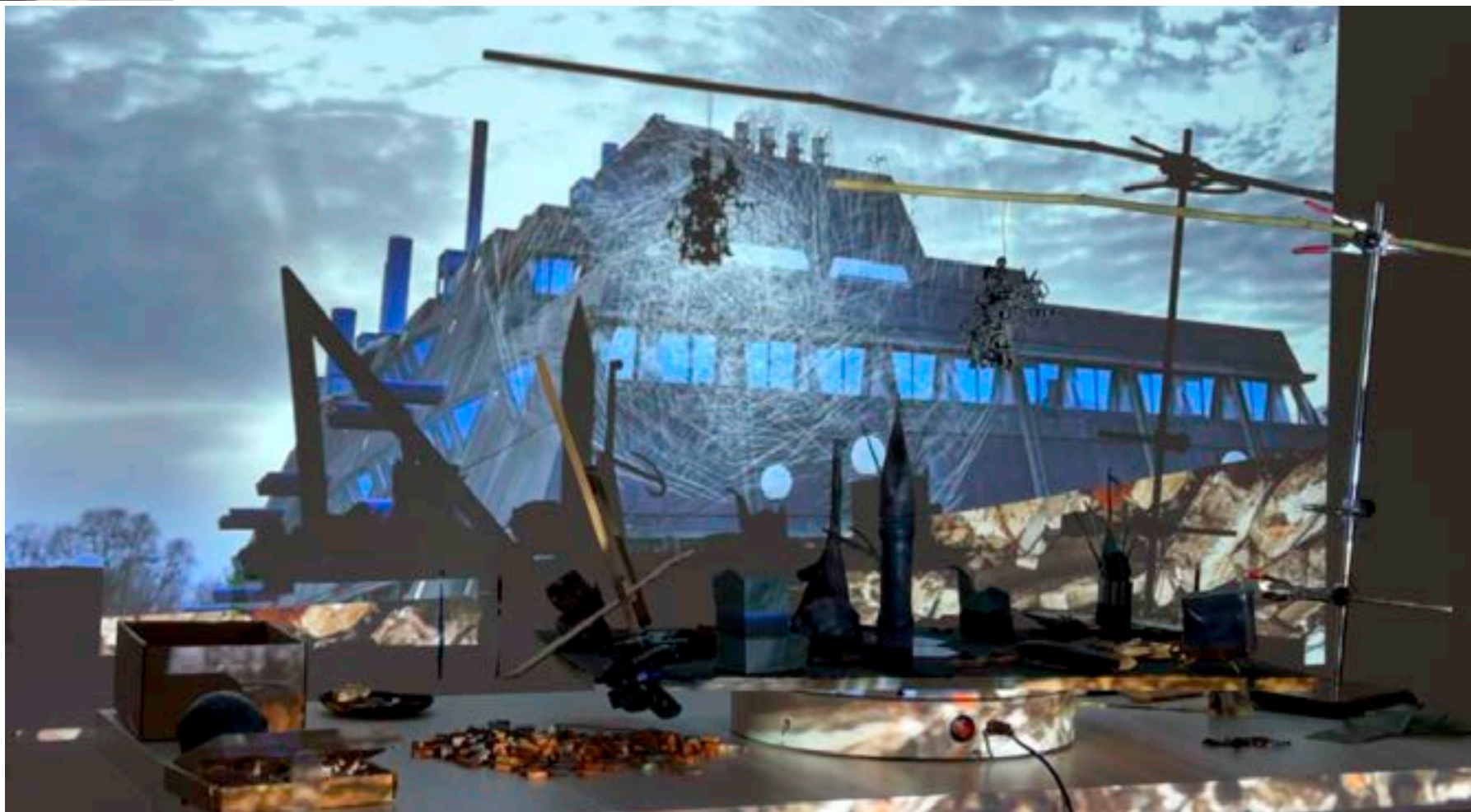

Marcus Neustetter, Liviu Bulea - Studio Vienna

THE ZoNE - eXpanding possibilities hand-code

III II MARCUS NEUSTETTER

STUDIO GUESTS
studio dialogues

Vienna (Austria)
October 2023

Marcus Neustetter
with

John Zibb (AT)
Vasili Sofiadellis (ZA)

Liviu Bulea (RO)



menu back next

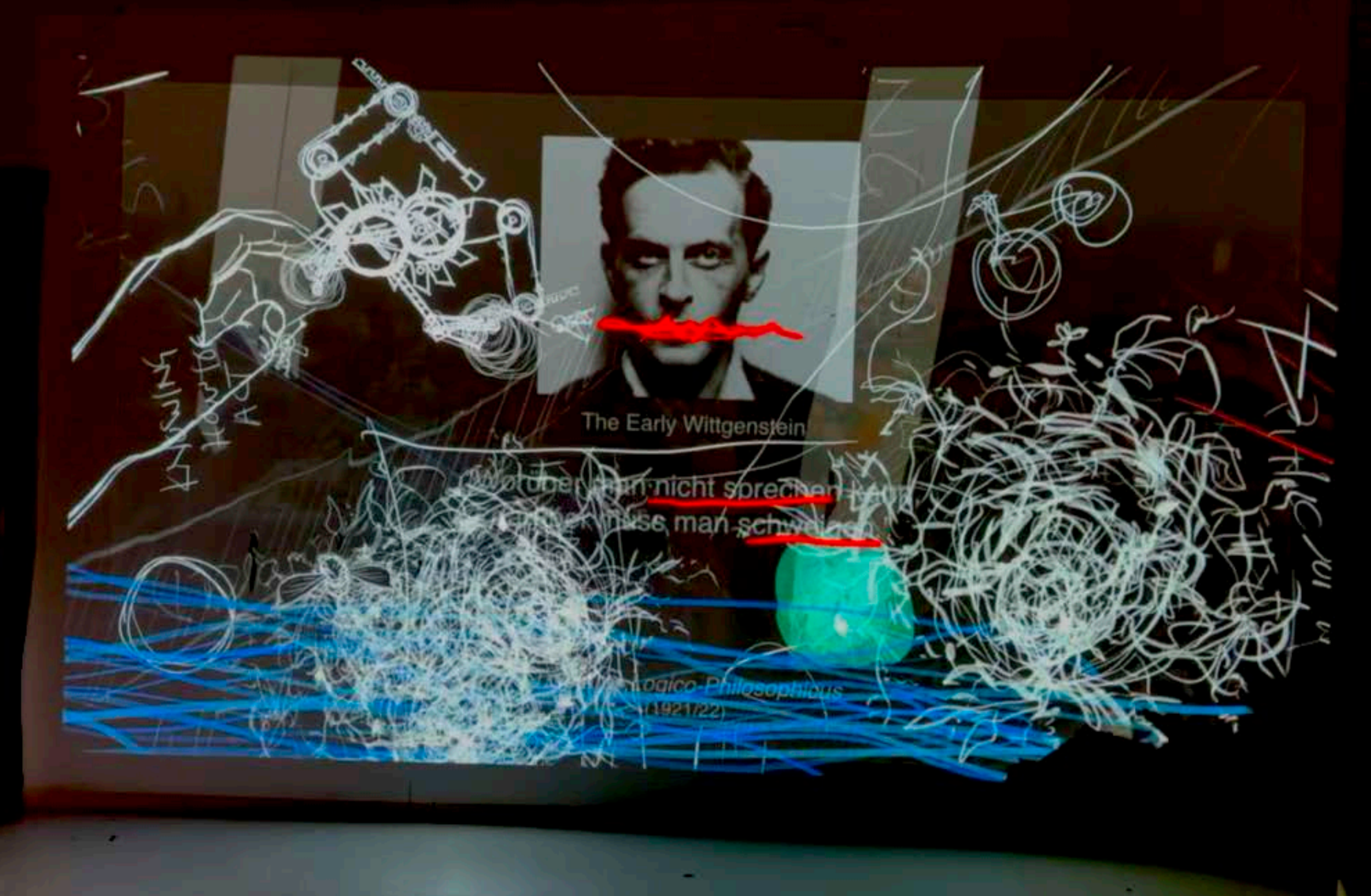

Marcus Neustetter, Johannes Jaeger, John Zibb, Vasili Sofiadellis - Studio Vienna

Marcus Neustetter, John Zibb - Studio Vienna

PUSHING THE BOUNDARIES
Agency, Evolution, and
The Dynamic Emergence of Expanding Possibilities

17.11.2023, 16:00 // Studio Lace | Neustetter
Viktor-Christ-Gasse 10, 1050 Vienna



Bronwyn Lace, Marcus Neustetter - Studio Vienna

#2
Studio

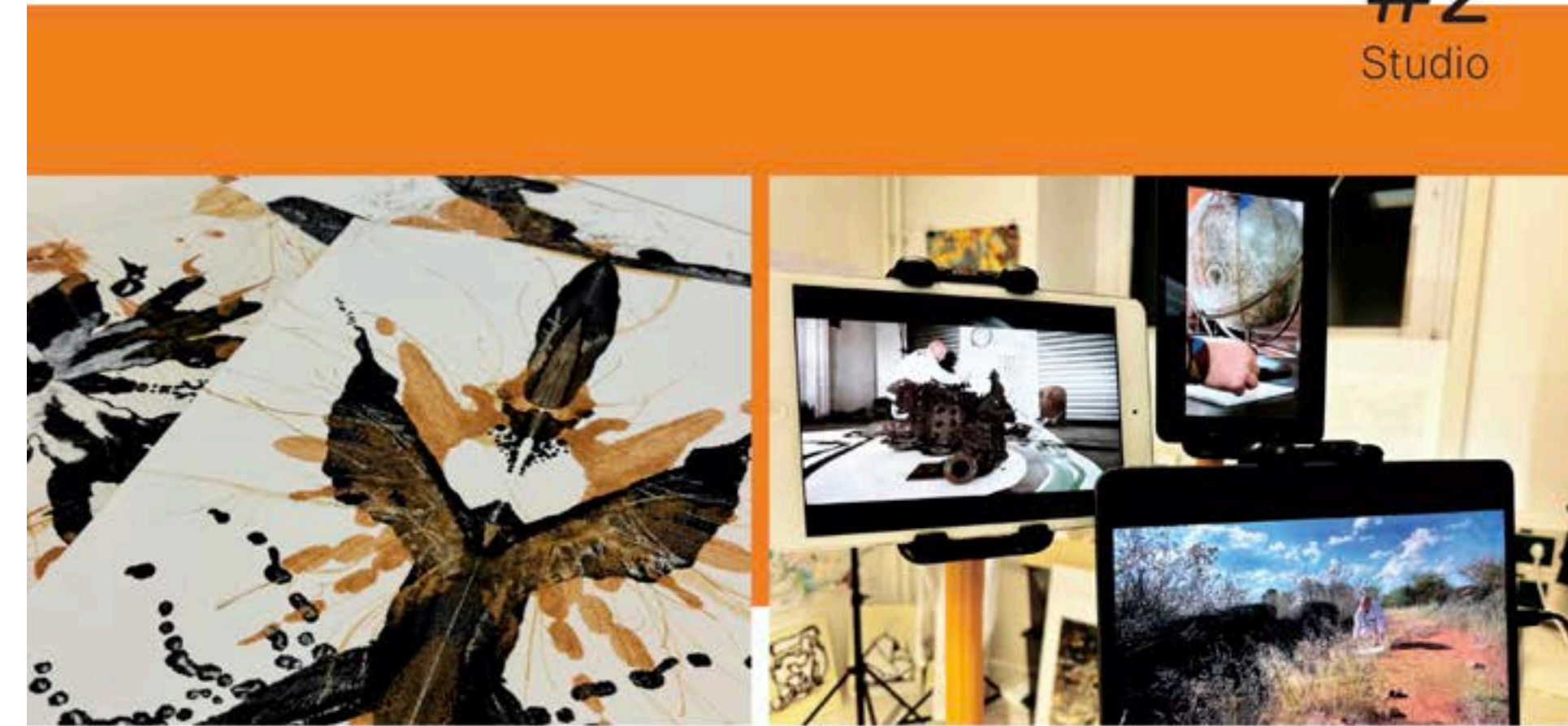

Photo by Bronwyn Lace, Courtesy of Studio Lace | Neustetter

Photo by Marcus Neustetter, Courtesy of Studio Lace | Neustetter

STUDIO EXHIBITION
works processing by
Lace & Neustetter

Vienna (Austria)
November 2023

during Vienna Art Week
at the Creative Cluster

“Studio Exhibition/
Atelierausstellung”
Bronwyn Lace &
Marcus Neustetter

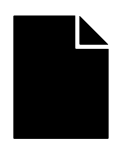
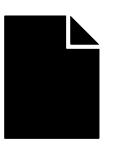



PUSHING THE BOUNDARIES
Agency, Evolution, and
The Dynamic Emergence of Expanding Possibilities

13.11.2023, 15:00 // Zentrum Fokus Forschung
Rustenschacherallee 2-4, 1020 Vienna

#1

Lecture Performance

A 'less-used' toolbox for everyone
Four tools to achieve negative capability, without any irritable reaching after fact and reason.

[CHAOS] — *The instrument of instability*
Life is fragile, always poised at the edge of the next surprise, if surprise is what we seek, we make ourselves vulnerable. Only the vulnerable are receptive, ready to respond to the unexpected. In mathematics, instability means bifurcation — the creation of new dynamic attractors. The state of being near bifurcation is called a state of criticality. The instrument is called through bifurcation. It sensitises us to what is around us, through listening and with ourselves, those around us through listening and poised, a...

Ontology of the
"Undefinable"
the ZoNE

FRAGMENTS
PRESENTATION
Touching on the
ontology of the
undefined

Zentrum Fokus
Forschung,
Angewandte
Vienna (Austria)
November 2023

by Lace & Neustetter



Bronwyn Lace, Marcus Neustetter - ZFF Vienna

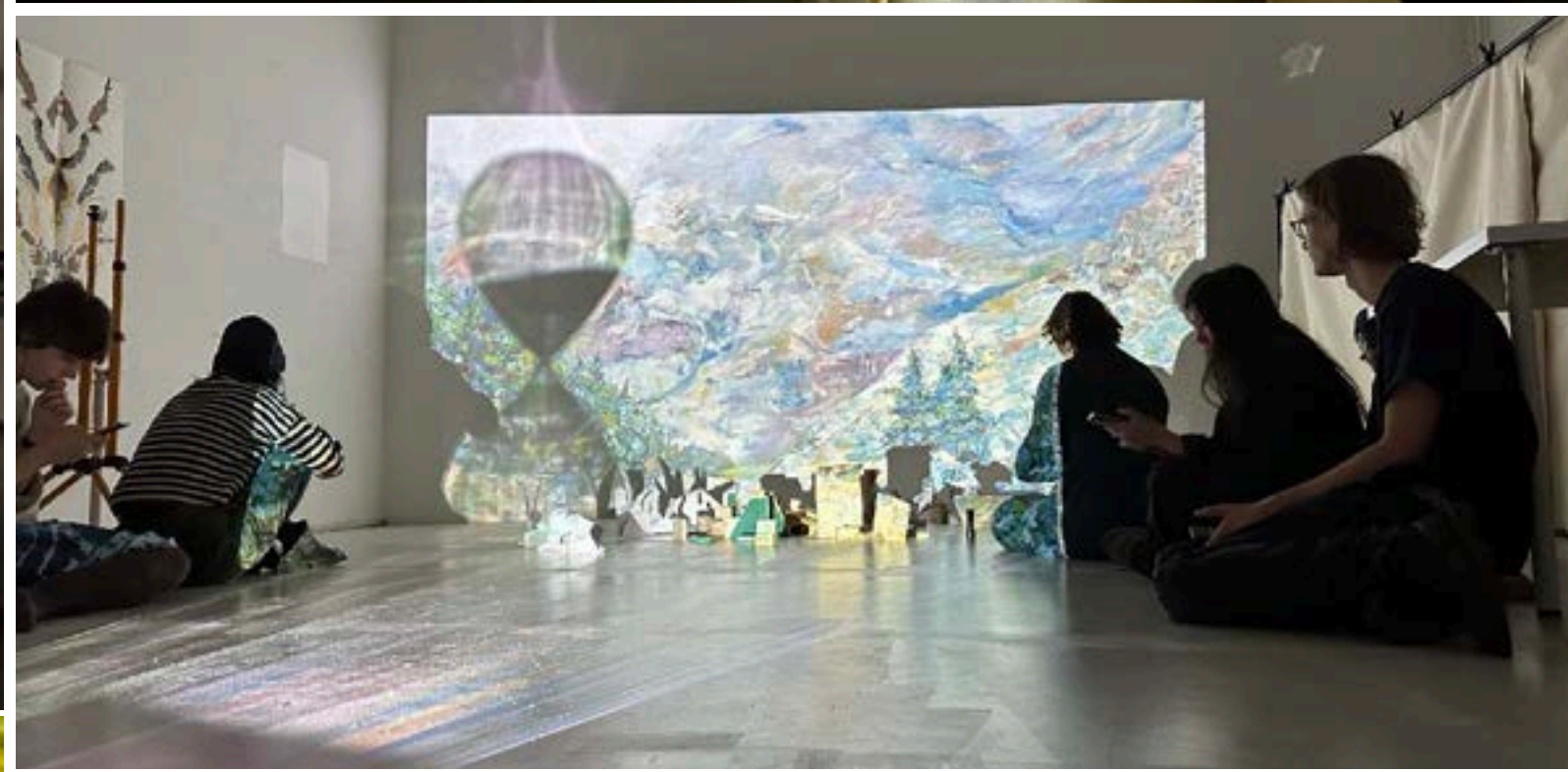
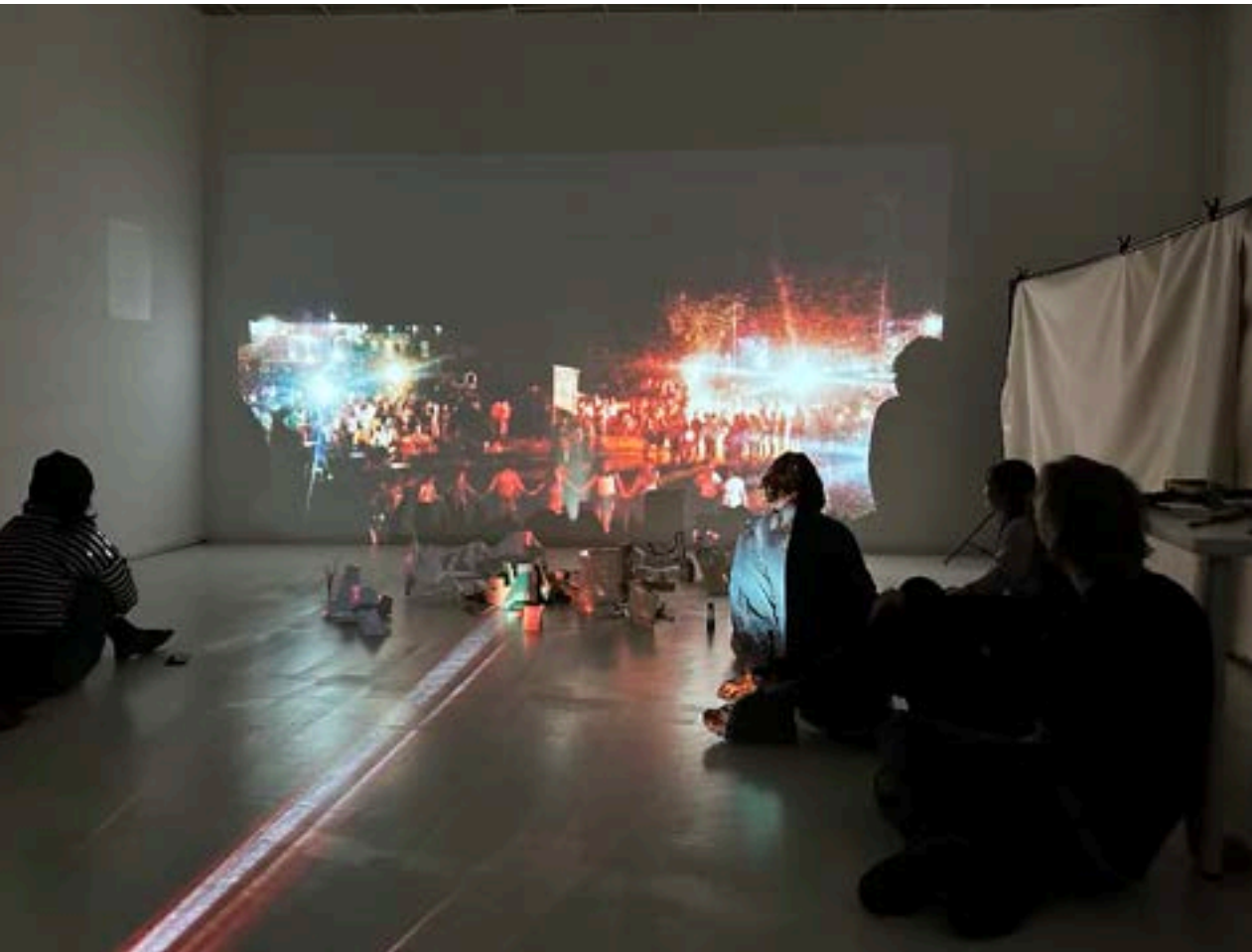

THE ZoNE - eXpanding possibilities
hand-code
III II MARCUS NEUSTETTER

IN STUDIO
processing research through practice

Vienna (Austria)
November 2023

Marcus Neustetter in studio dialogue with collaborators including students from the Repatriates Project at the Central European University and Khadija Zinnenburg Carroll



menu back next

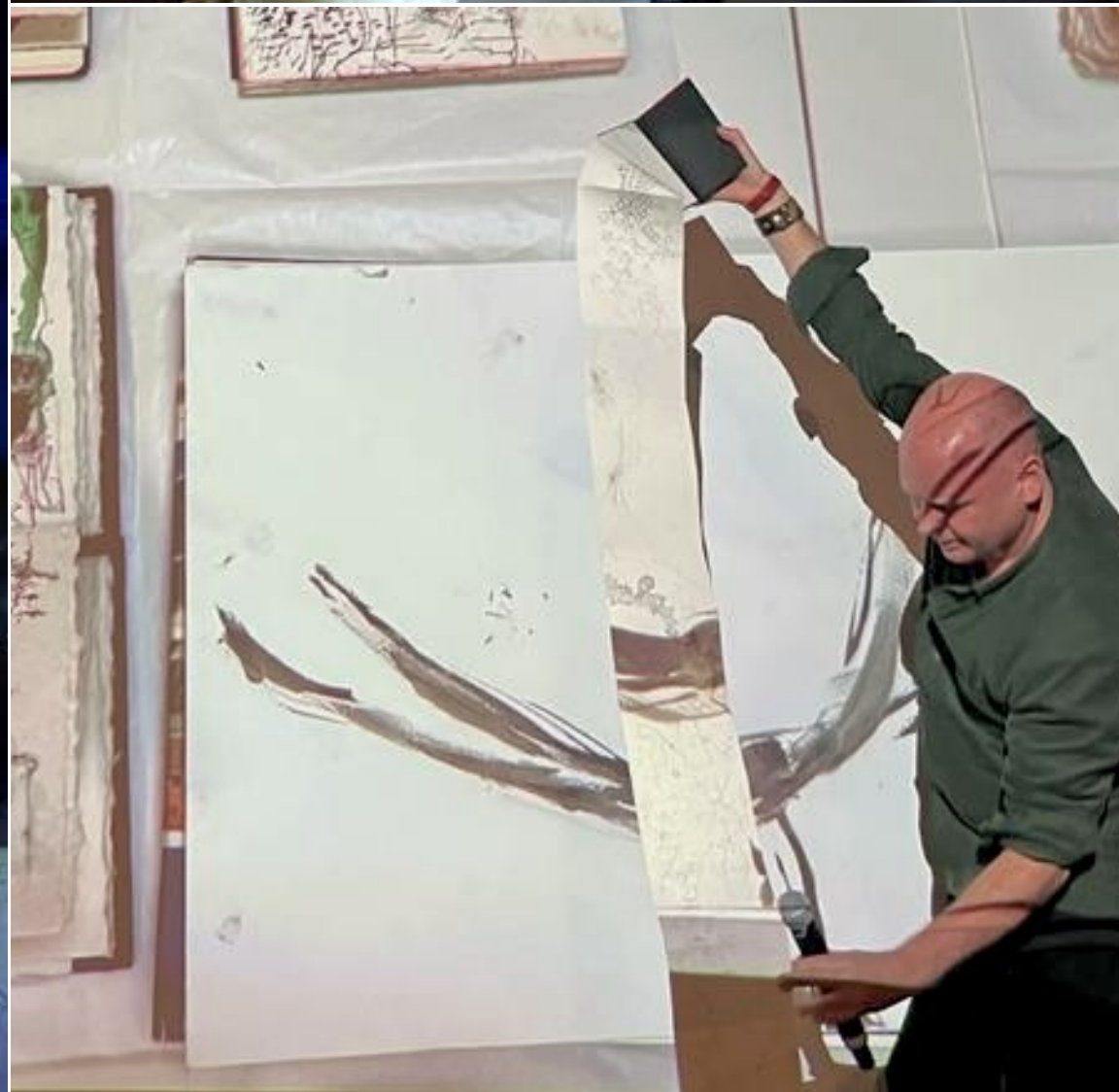

THE ZoNE - eXpanding possibilities

hand-code

III II MARCUS NEUSTETTER

HAND-CODE PRESENTATION
PROCESSING

Albert Kahn Museum
Paris (France)
November 2023

by Marcus Neustetter
in partnership with the centre for the Less Good Idea,
Université Paris 8 and the Albert Kahn Museum

Photo: Julien Faure-Conorton

menu back next

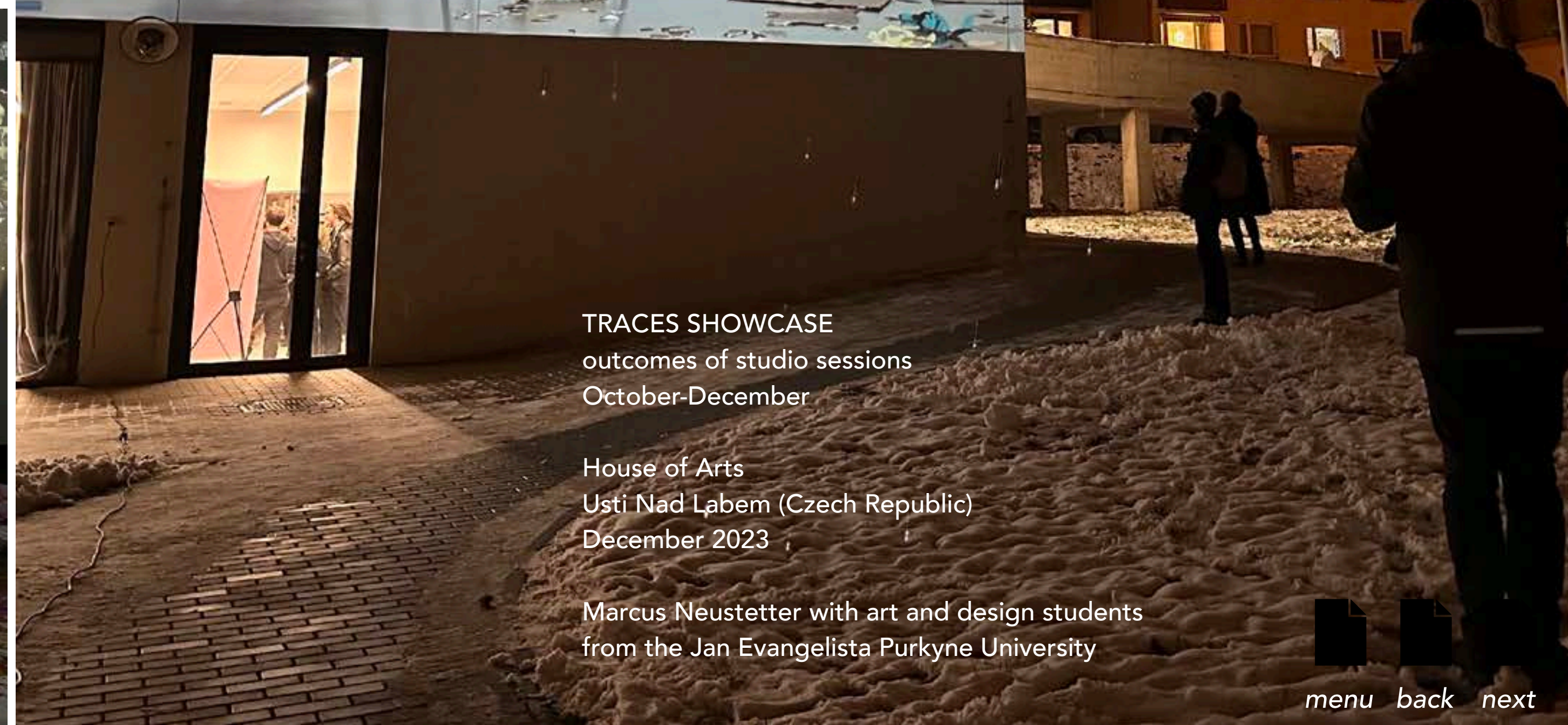

TRACES SHOWCASE
outcomes of studio sessions
October-December

House of Arts
Usti Nad Labem (Czech Republic)
December 2023

Marcus Neustetter with art and design students
from the Jan Evangelista Purkyně University

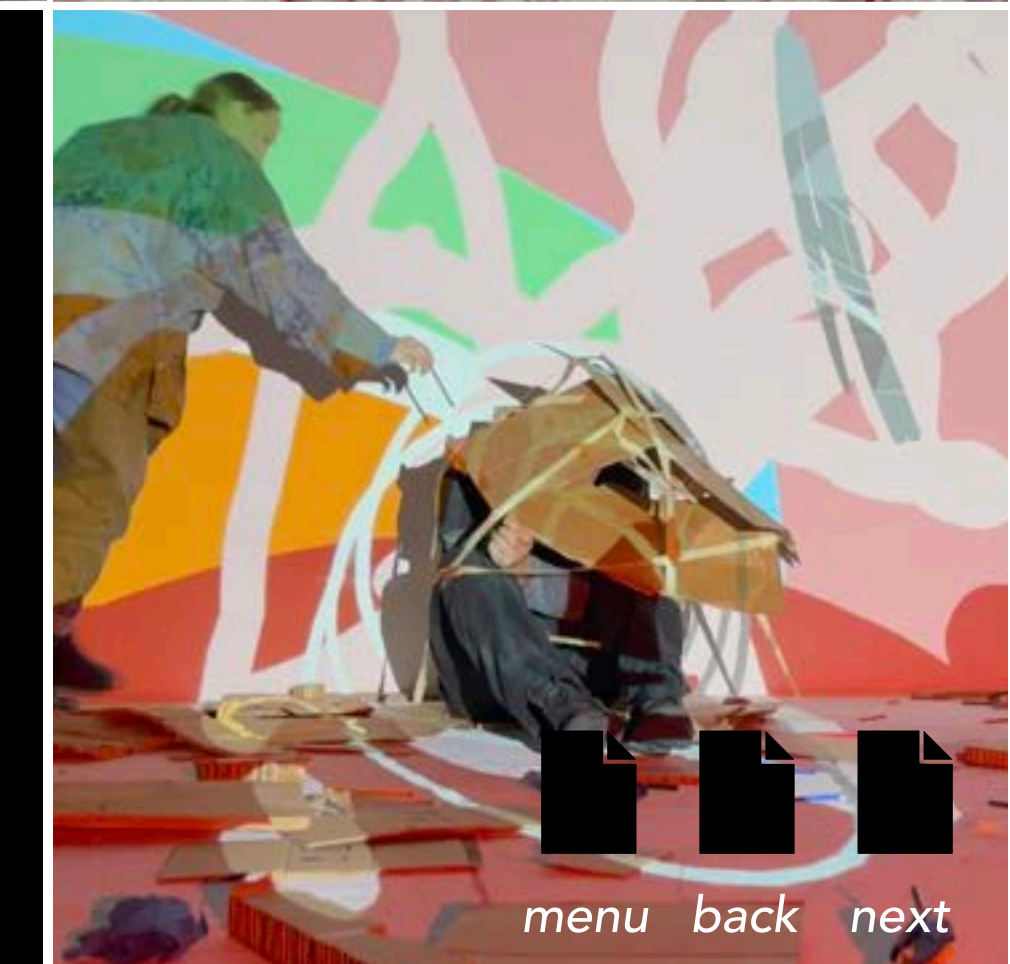
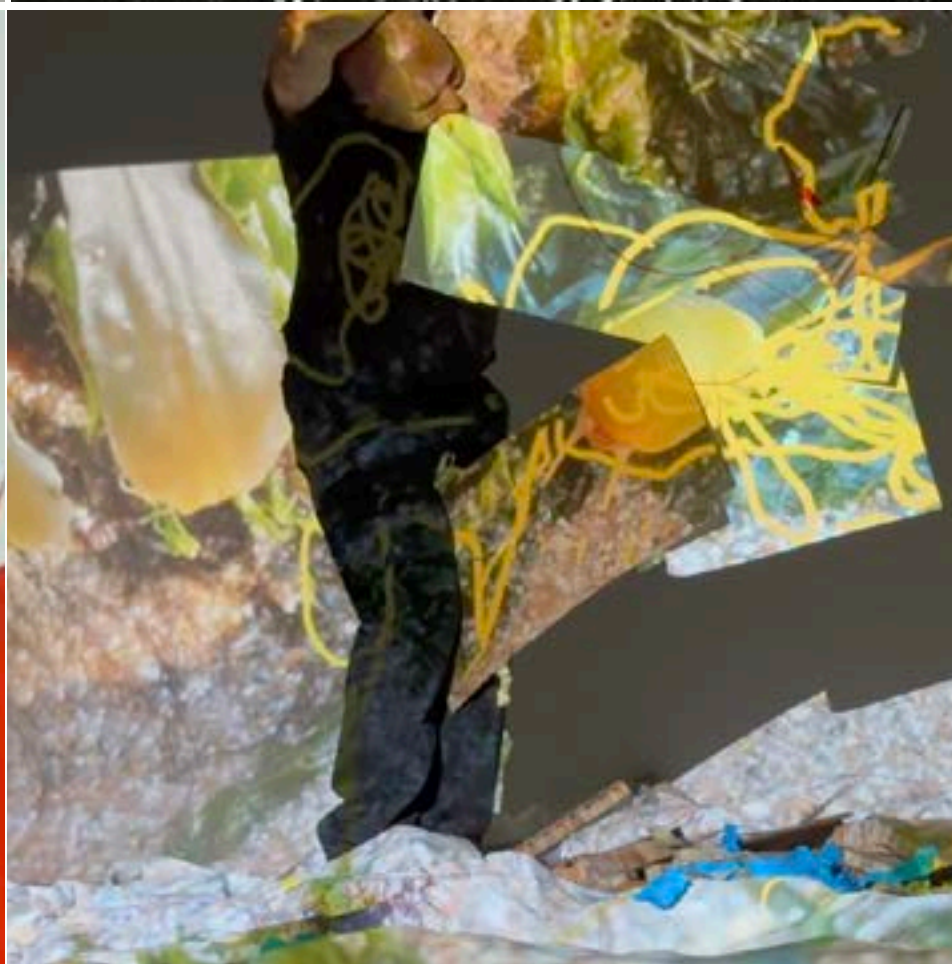
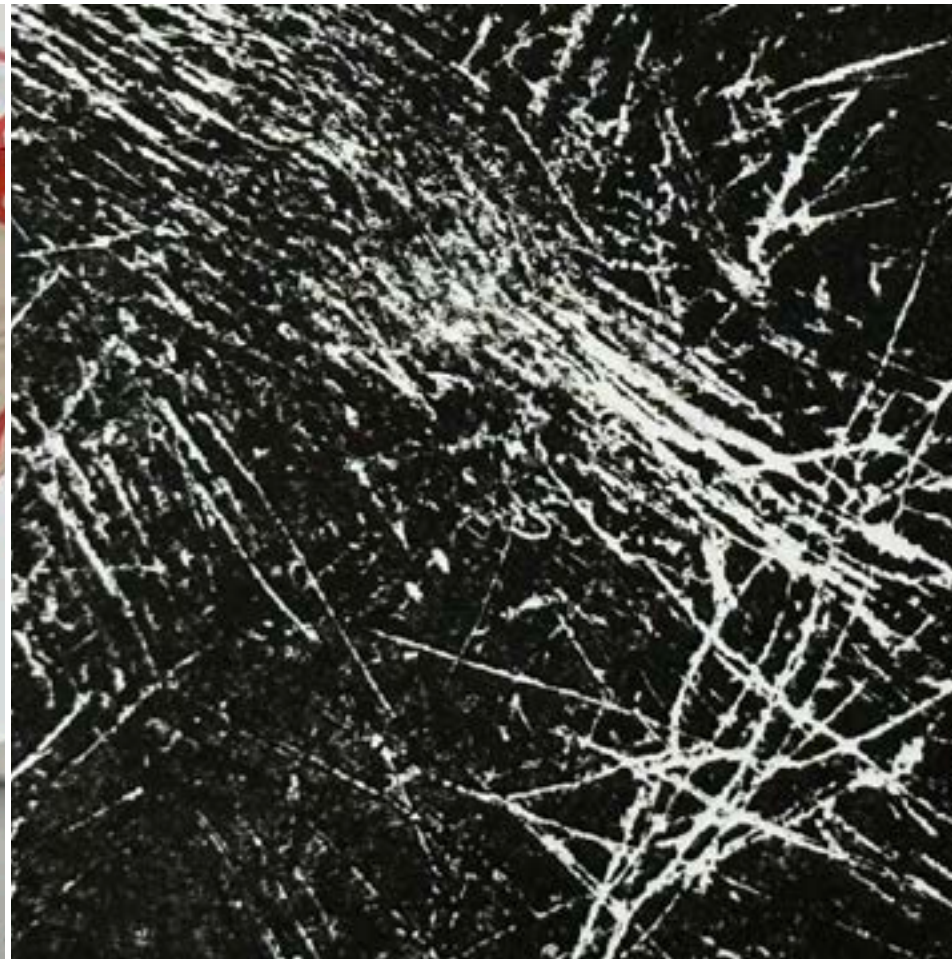

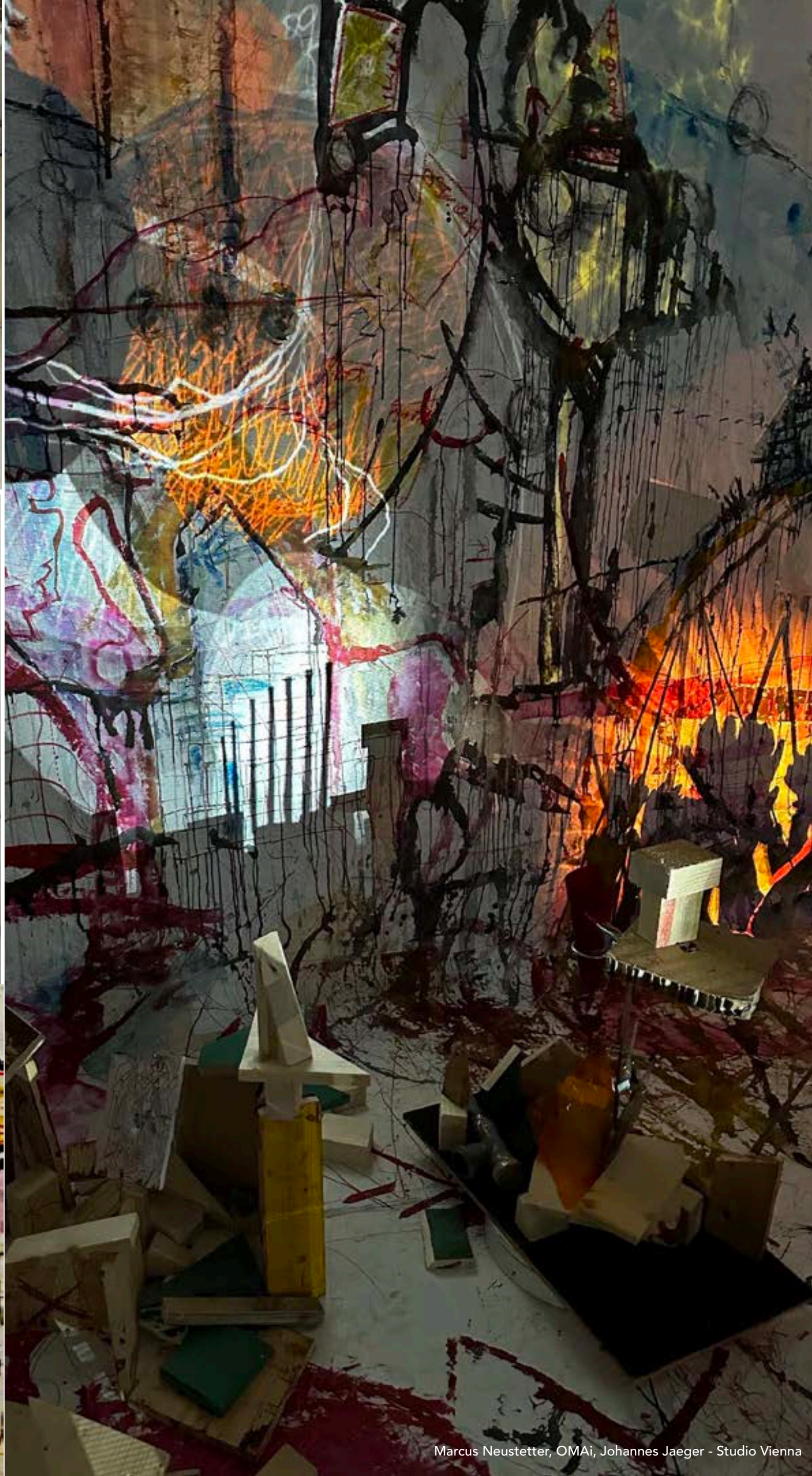

Marcus Neustetter, OMAi, Johannes Jaeger - Studio Vienna



THE ZoNE - eXpanding possibilities
hand-code
III II MARCUS NEUSTETTER

CODED MAPPING
studio dialogue maps

Vienna (Austria)
January 2024

OMAi, Marcus Neustetter and Johannes Jaeger



menu back next

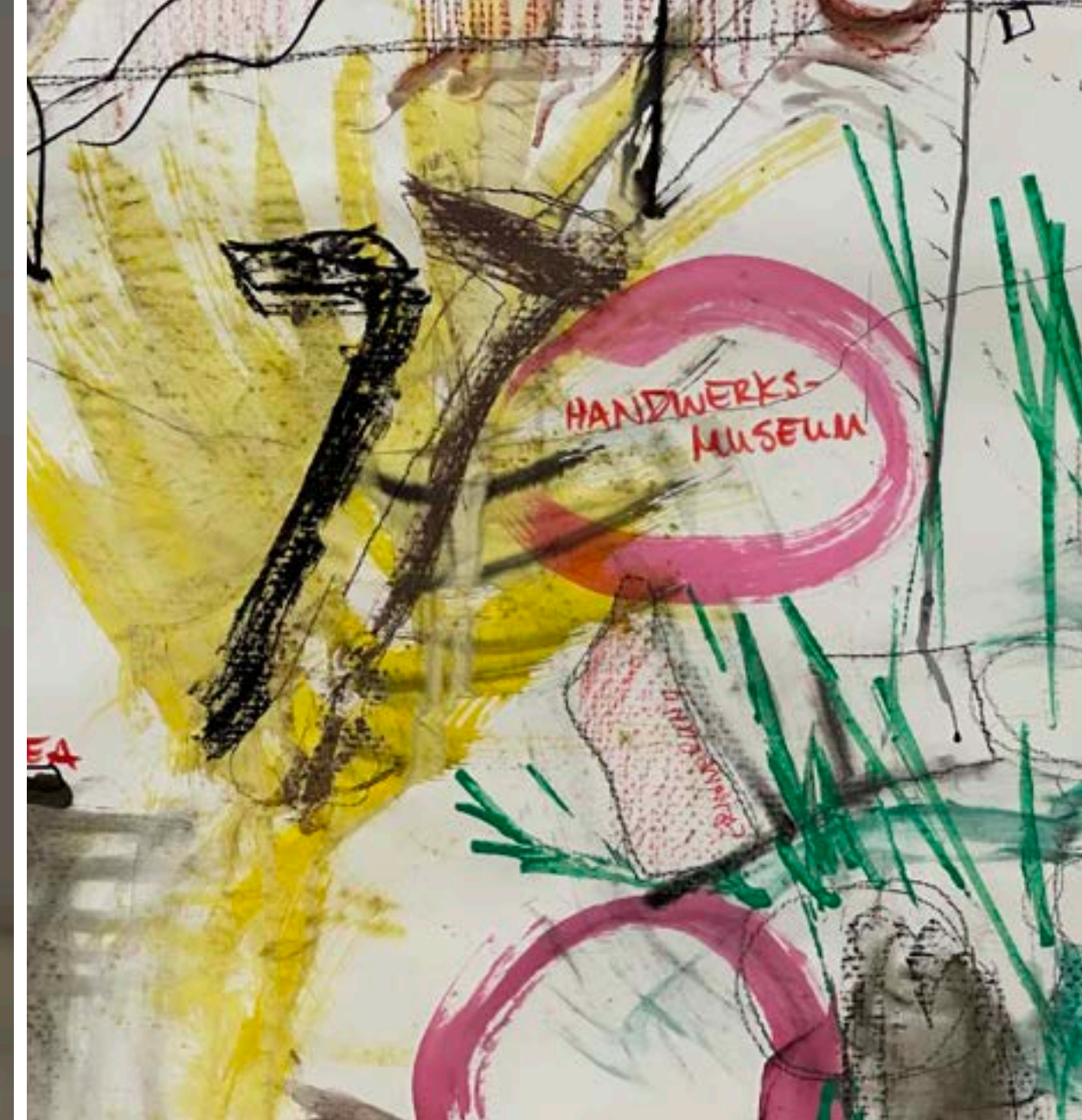

CODED MAPPING
studio dialogue maps

Vienna (Austria)
January 2024

Marcus Neustetter, Karin Reinprecht
and Salvatorhaus - focus Murau

THE ZoNE - eXpanding possibilities

hand-code

III II MARCUS NEUSTETTER

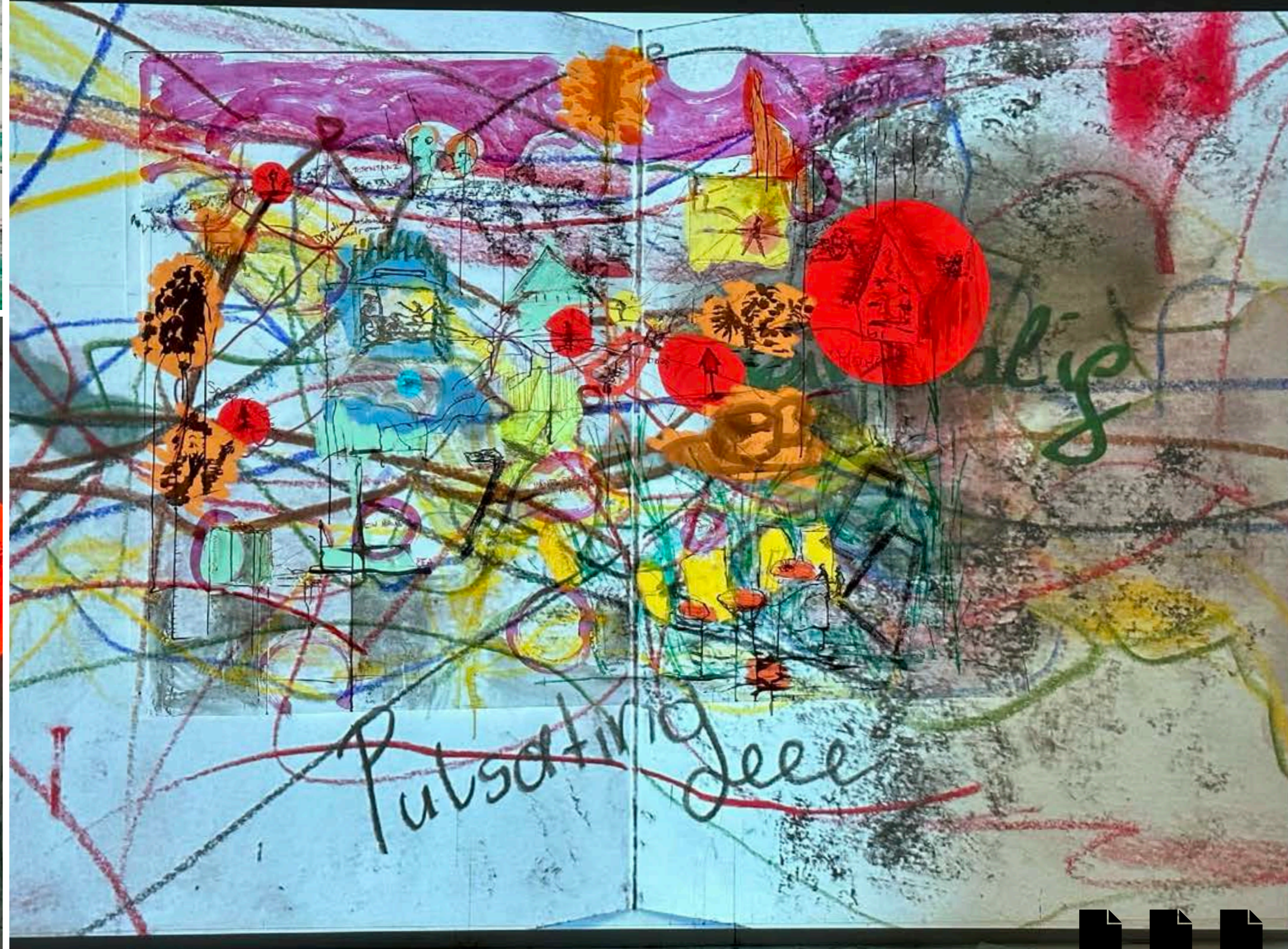

menu back next

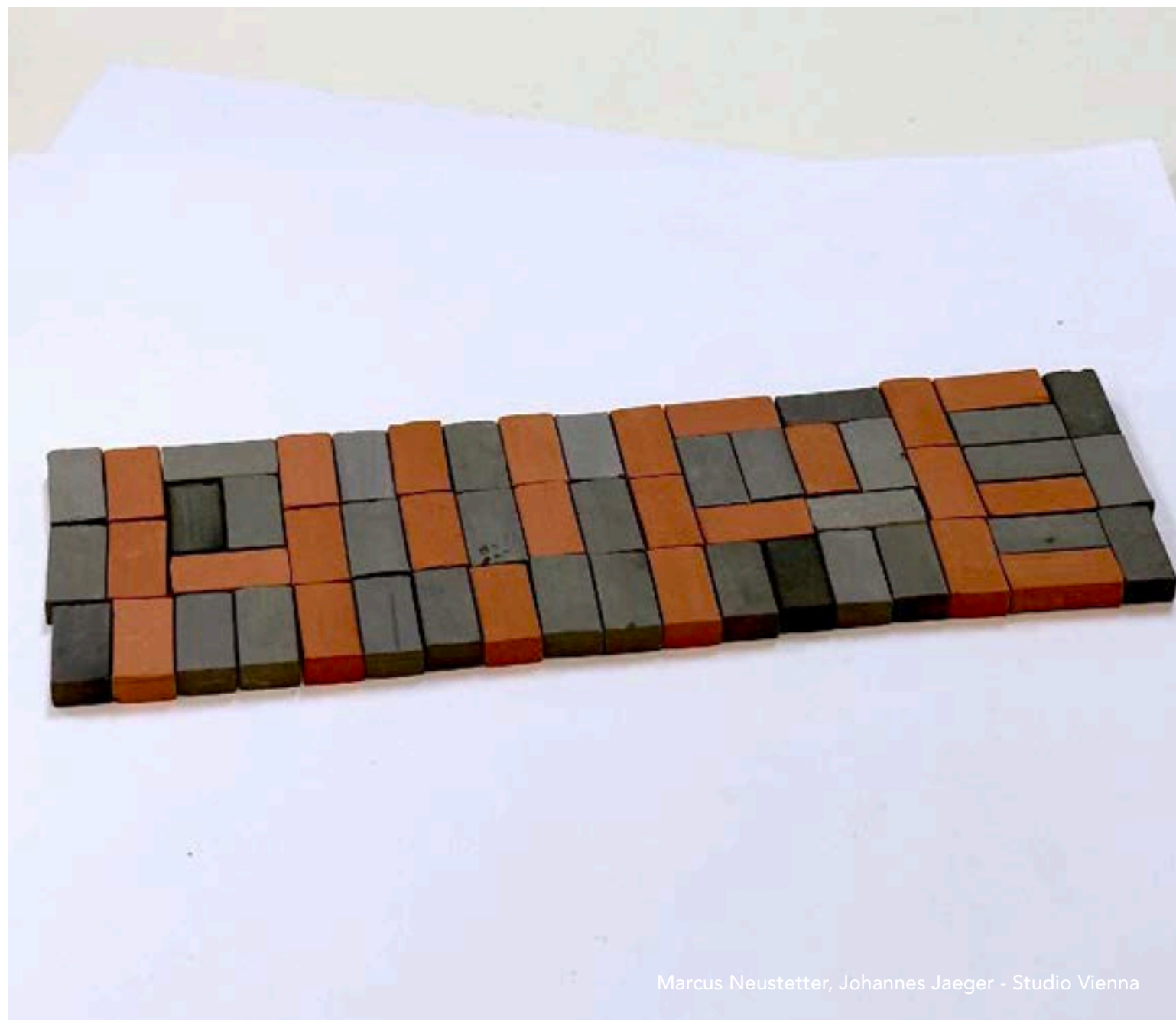
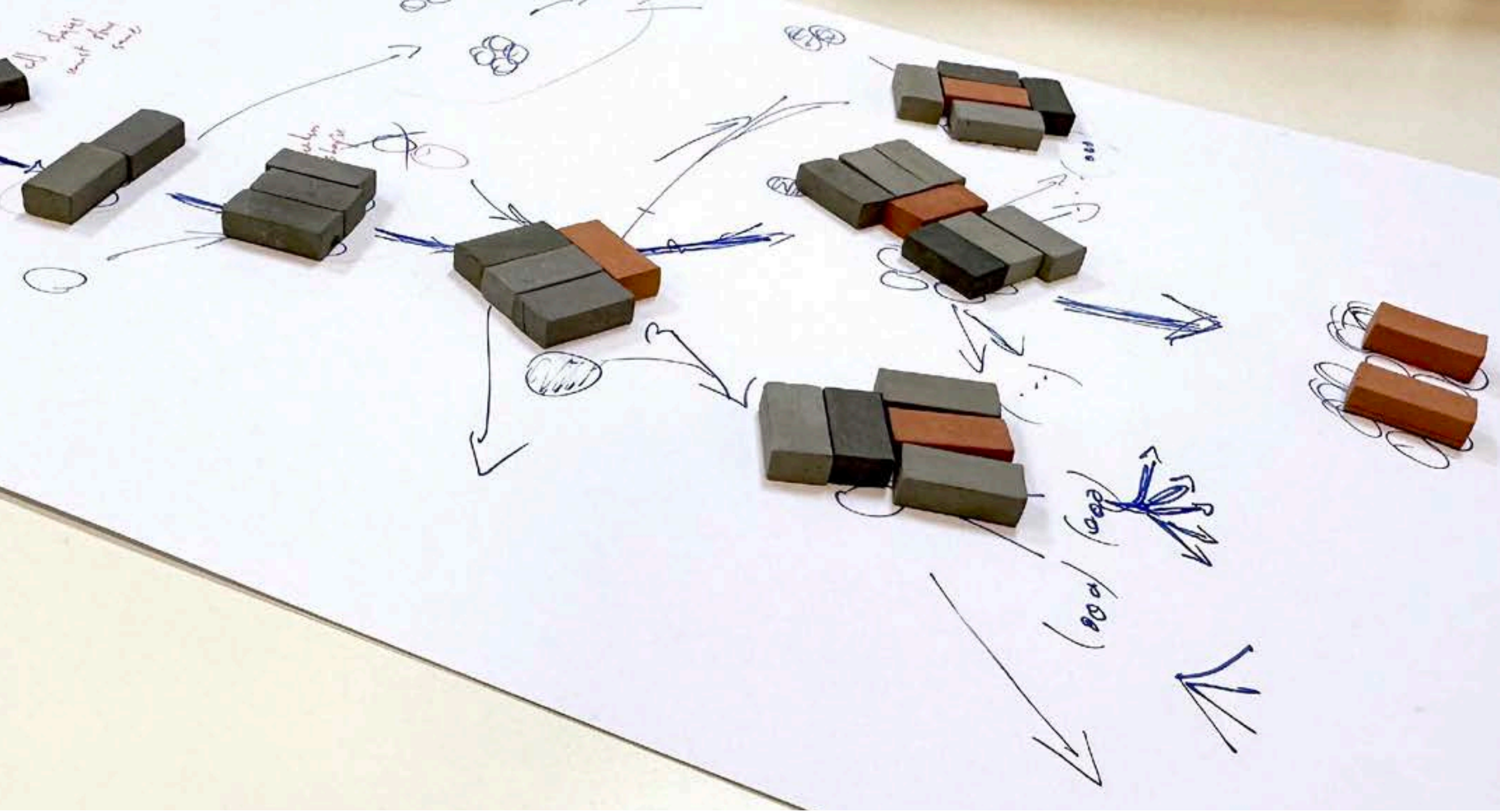

Marcus Neustetter, Johannes Jaeger - Studio Vienna

THE ZoNE - eXpanding possibilities
hand-code

III II MARCUS NEUSTETTER



DRAWING FORM
illustrating concepts

Vienna (Austria)
February 2024

Marcus Neustetter and
Johannes Jaeger



menu back next

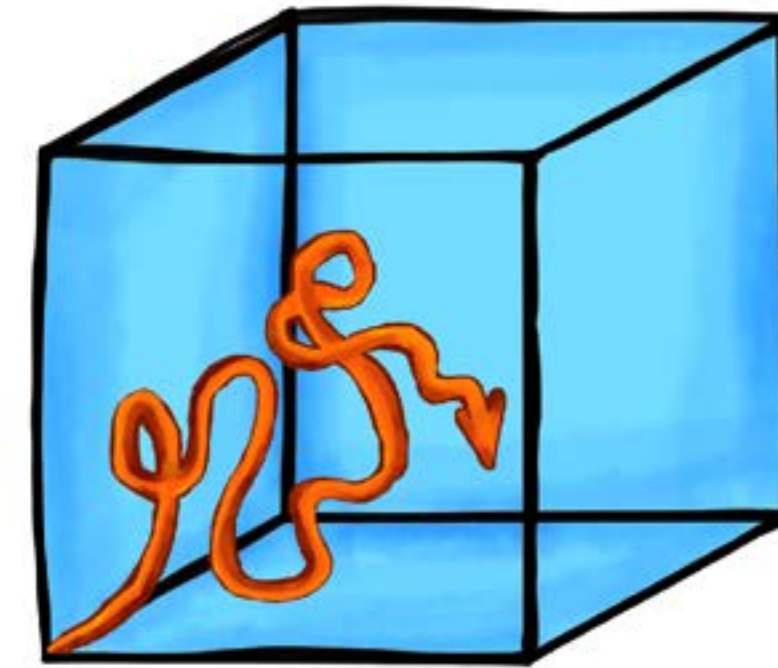
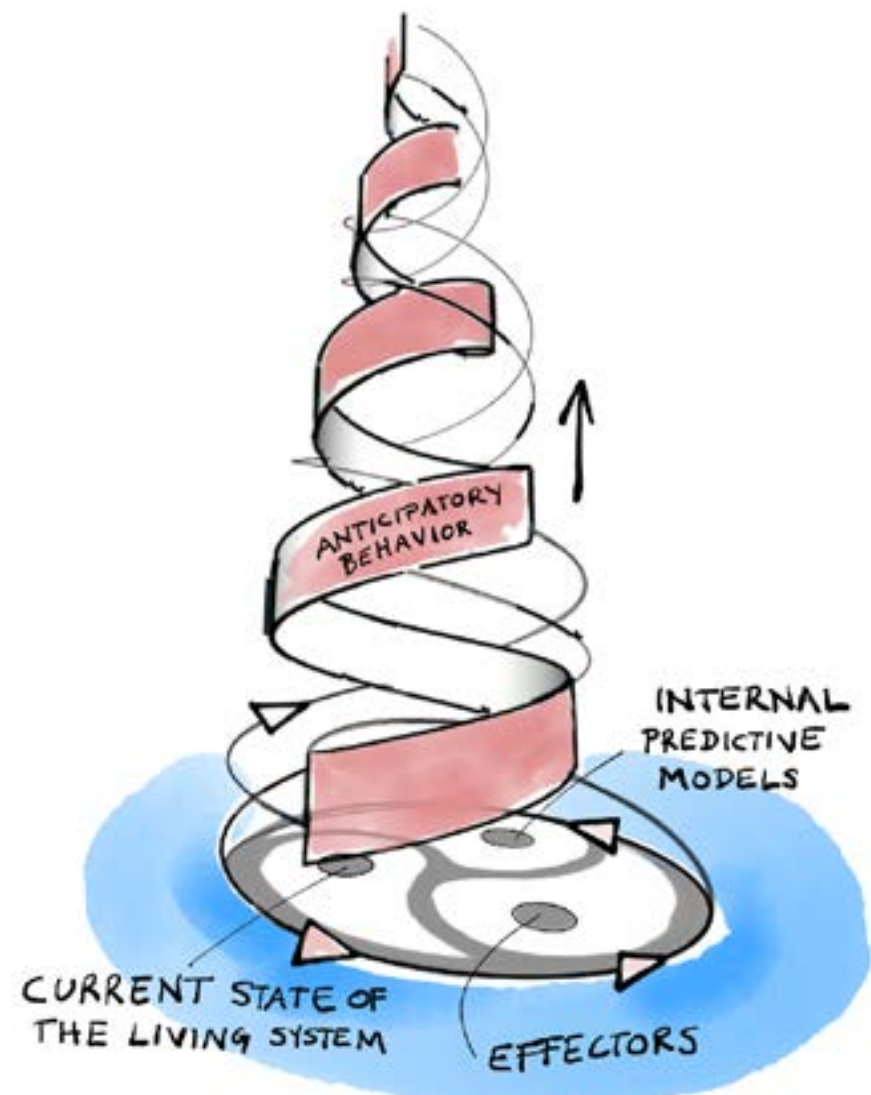
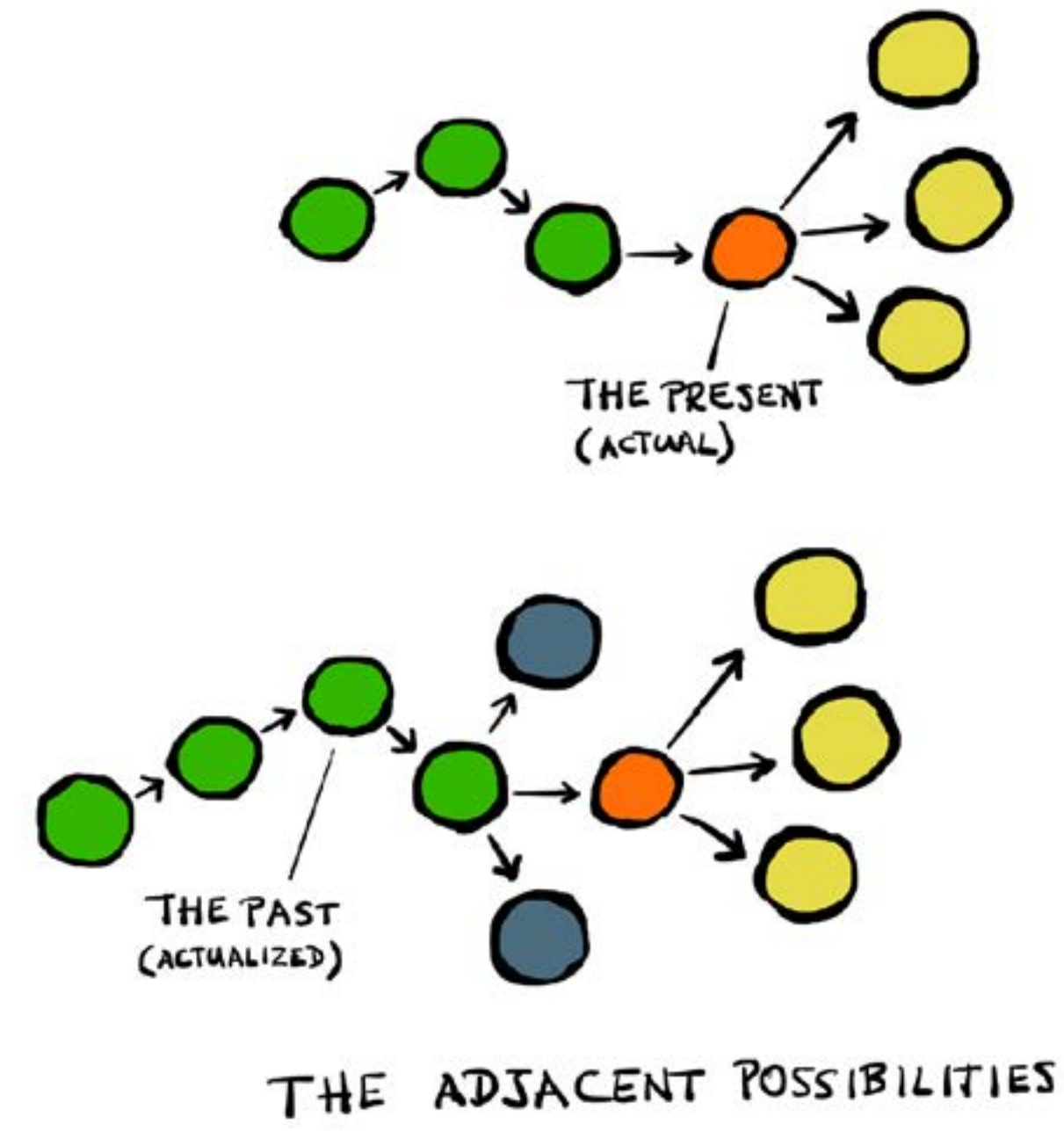
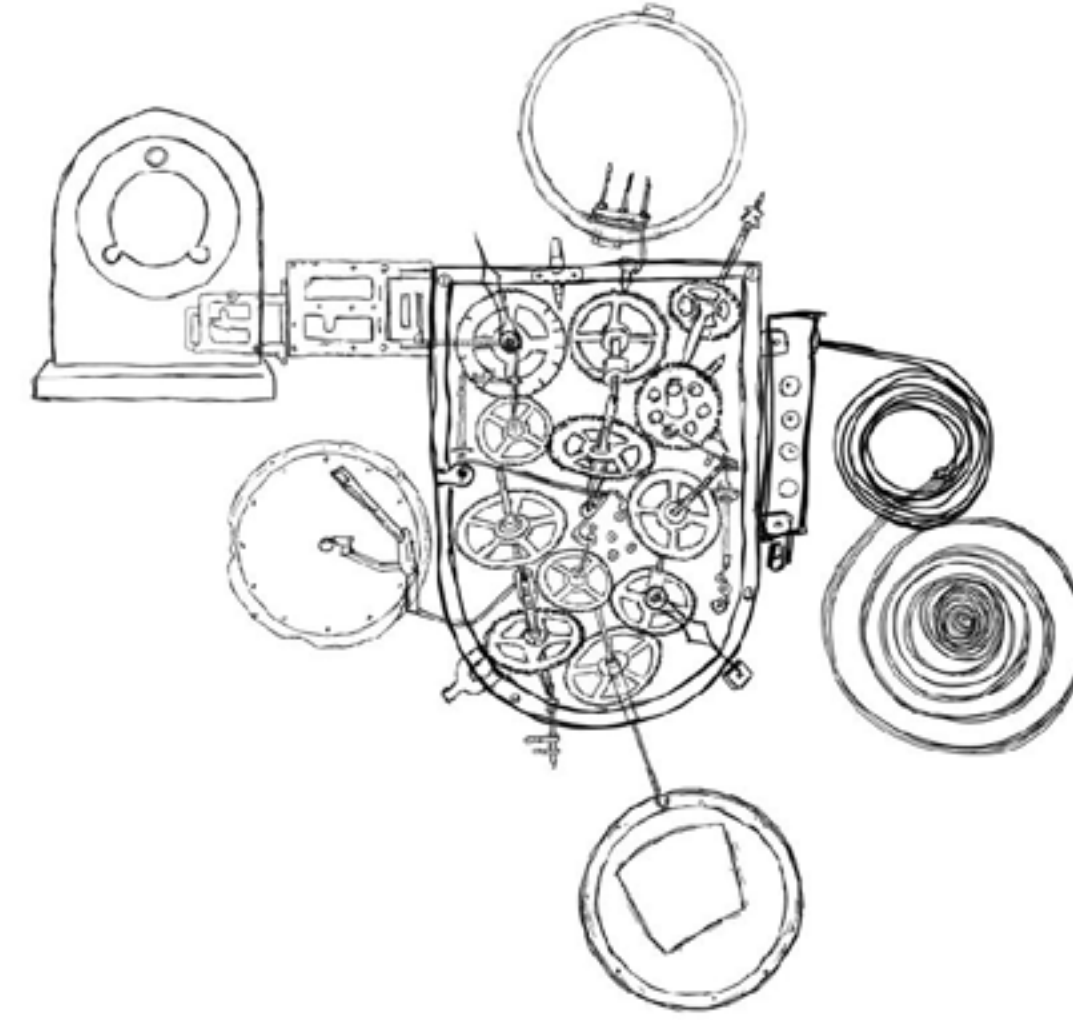
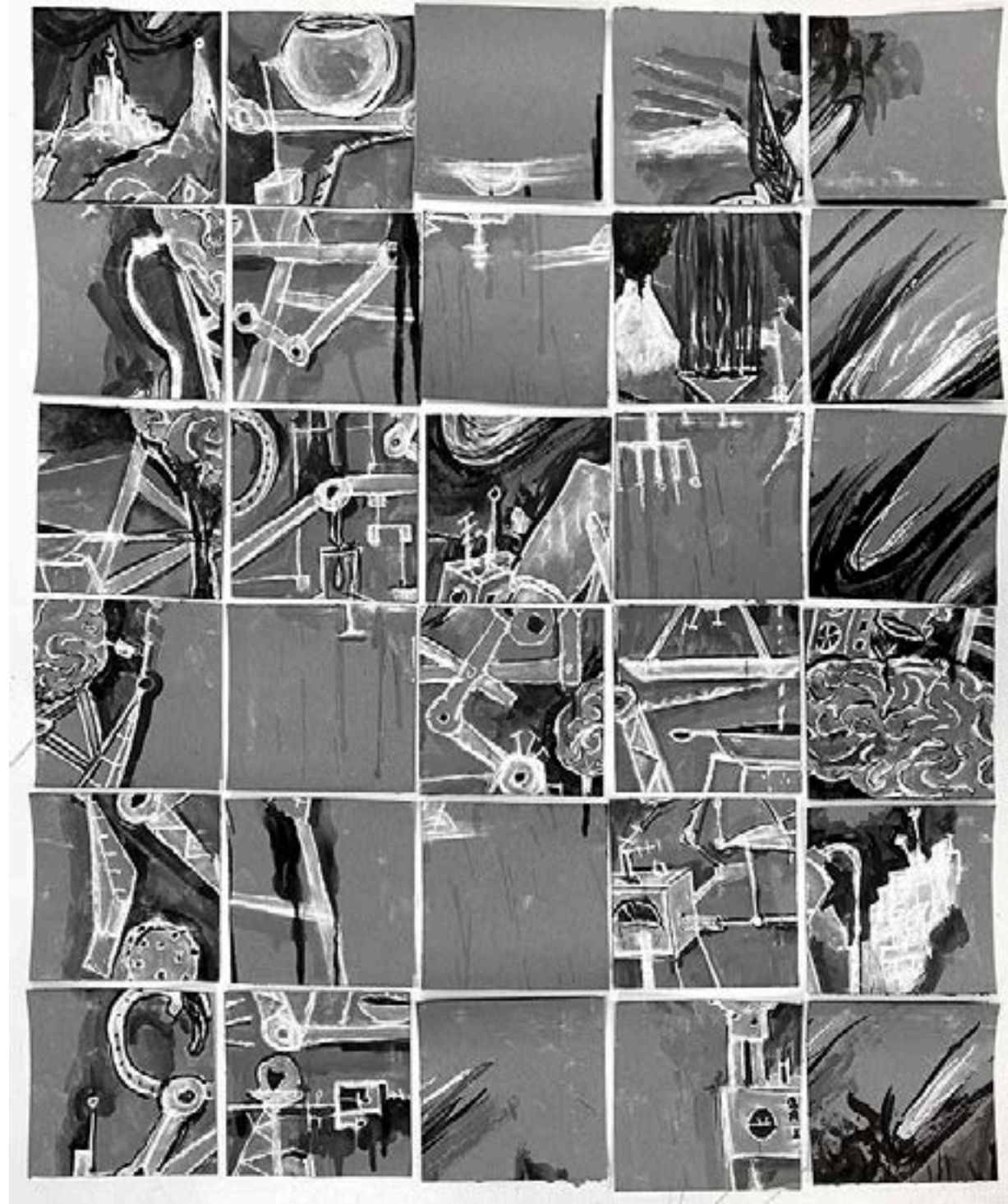
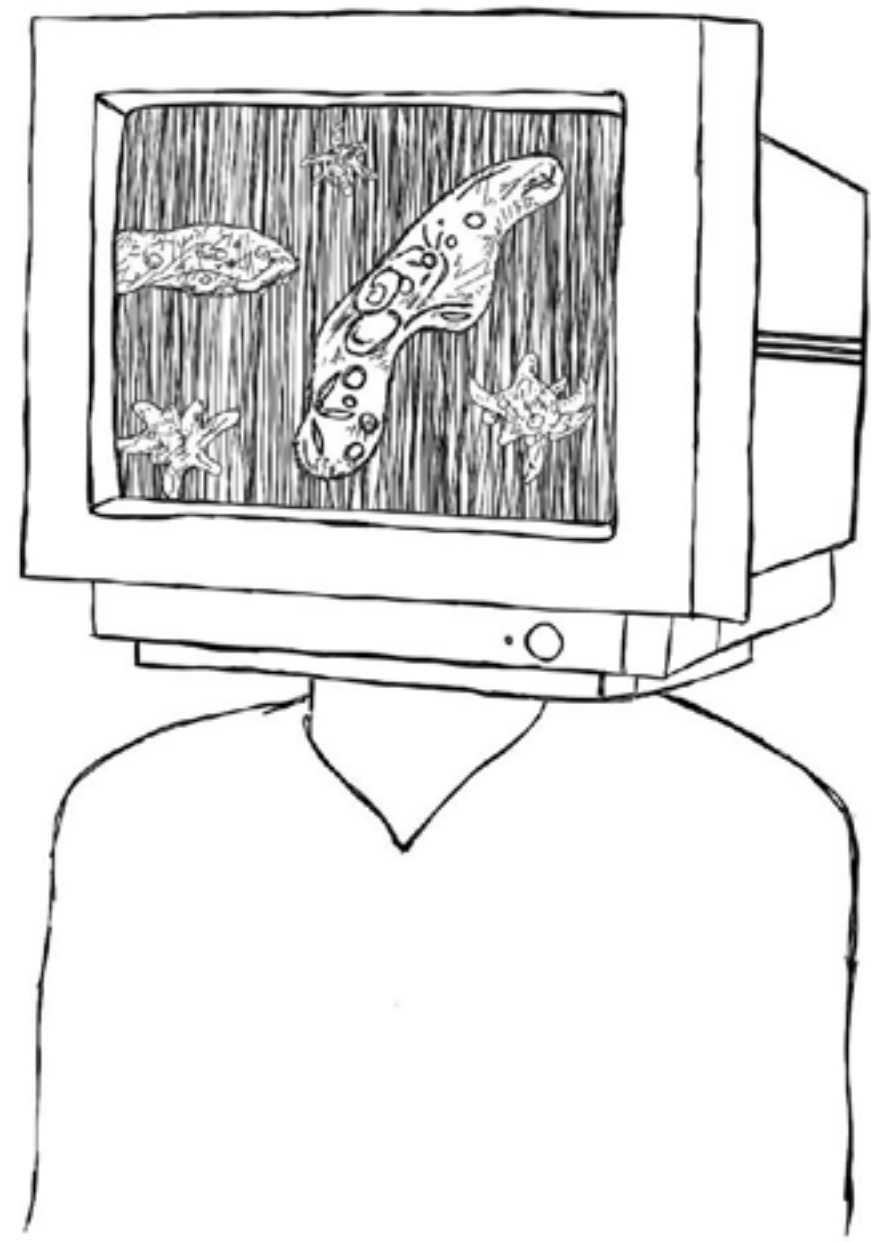

THE TRADITIONAL VIEW





THE ZoNE - eXpanding possibilities
hand-code
III II MARCUS NEUSTETTER



STUDIO PROCESSING
production and
projecting into
2024-2025

Vienna (Austria)
February 2024

Marcus Neustetter,
Bronwyn Lace,
Johannes Jaeger,
Basak Senova